

*P Bass
Guitar Kit Assembly
Instructions*



WARNING

Some dust created by power sanding, sawing, grinding, drilling, and other construction activities contains chemicals known to the State of California to cause cancer, birth defects or other reproductive harm.

Some examples of these chemicals are:

- *Lead from lead-based paints.*
- *Crystalline silica from bricks, cement, and other masonry products.*
- *Arsenic and chromium from chemically treated lumber.*

Your risk from these exposures varies, depending on how often you do this type of work. To reduce your exposure to these chemicals: work in a well ventilated area, and work with approved safety equipment, such as those dust masks that are specially designed to filter out microscopic particles.

Warning

Always wear safety glasses or goggles when operating equipment. Everyday glasses or reading glasses are not safety glasses. Be certain the safety glasses you wear meet the appropriate standards of the American National Standards Institute (ANSI). Because there are various ways to cut and join wood, you can make substitutions for the methods stated in this manual. We try to suggest the easiest methods possible.

However, only you know your skills with each piece of machinery. Never compromise your safety by using a cutting method with which you are not comfortable. Instead, find an alternative approach that will yield the same result.

Warning

These instructions assume that you are familiar with the safe operation and use of woodworking machinery and woodworking tools, and understand the techniques used to assemble this project. If you do not qualify for both of these criteria, STOP building this project for your own safety. Read and understand the owner's manual for the machinery you intend to use, take a woodworking class or visit your local library for more information. Woodworking machinery and tools are inherently dangerous because they use sharp edges that can and will cause serious personal injury including amputation and death. Do not underestimate the ability of these tools and machinery to cause injury. Never operate any tool without all guards in place and always wear approved safety glasses. For your own safety, please heed this warning.

Contents

Contents.....	- 2 -
1 Introduction	- 3 -
1.1 Material Check List.....	- 5 -
1.2 Additional tools/materials required:	- 7 -
2 Mockup and Fit Check.....	- 1 -
2.1 Check Guitar Body & Neck mounting holes.....	- 1 -
2.1.1 Drilling the Mounting Holes in the Guitar Body.....	- 1 -
2.2 Checking the Mounting Holes in the Neck.....	- 2 -
2.2.1 Drilling Mounting Holes in the Neck	- 2 -
2.3 Check the Neck to the Body Fit.....	- 2 -
2.4 Fit check & alignment of the Pick Guard with Controls (item 2 on materials list).....	- 3 -
2.5 Fit check the Bridge.....	- 3 -
2.6 Check Strap Pins.....	- 3 -
2.7 Check Tuner Alignment.....	- 4 -
2.8 String Tee Position	- 4 -
2.9 Mockup and Fit Check complete!	- 4 -
3 Finish	- 1 -
3.1 Finish Application Steps	- 2 -
3.1.1 Solid Color finish:	- 2 -
3.1.2 Pigmented Translucent, Gel stain or alcohol dye finish:.....	- 2 -
3.1.3 Penetrating Stain or water based dye finish:.....	- 2 -
3.2 Explanation of Sequence Steps:.....	- 2 -
3.2.1 Sanding the Body and Neck	- 2 -
3.2.2 Applying Grain Filler.....	- 3 -
3.2.3 Applying Sanding Sealer	- 3 -
3.2.4 Solid Color Primer	- 3 -
3.2.5 Burst and Translucent finishes.....	- 4 -
3.2.6 Clear Top coats.....	- 4 -
3.2.7 Buff finish	- 4 -
4 Assembly	- 1 -
4.1 Attach the Neck to the Body.....	- 1 -
4.2 Installing Component Wiring & Installation.....	- 1 -
4.2.1 Preparation of pickups.....	- 2 -
4.2.2 Pickguard Wiring & Installation	- 3 -

- 4.2.3 Bridge & Frame Ground Wire Installation - 3 -
- 4.3 Installing the Nut..... - 3 -
- 4.4 Installing the Tuners..... - 4 -
- 4.5 Install the Strings..... - 4 -
- 4.6 Installing the Strap Pins..... - 5 -
- 4.7 Installing the String Retainer..... - 5 -
- 5 Setup - 1 -
- 5.1 Adjust the Guitar Neck: Truss Rod - 2 -
 - 5.1.1 Adjustment Check - 2 -
 - 5.1.2 Adjustment..... - 2 -
- 5.2 Bridge Saddle - 2 -
 - 5.2.1 Checking String Height - 3 -
 - 5.2.2 Bridge Saddle Adjustment..... - 3 -
- 5.3 Nut Action - 3 -
 - 5.3.1 Measurement..... - 3 -
 - 5.3.2 Nut Adjustment..... - 3 -
- 5.4 Pickup Height - 4 -
 - 5.4.1 Treble (G string) adjustment..... - 4 -
 - 5.4.2 Bass (E string) adjustment..... - 4 -
- 5.5 Intonation..... - 4 -
- 5.6 String Lubrication..... - 5 -
- 5.7 ...Other Hints - 5 -

1 Introduction

Thank you for purchasing a BYOGuitar.com guitar kit. This kit includes everything you need to build a complete custom guitar. In addition to the construction of your guitar, you will need to consider the finish – natural, solid color and possibly a design that will make your guitar unique. We suggest you do some research to determine your finish preferences. Procuring the required finishing materials,



TIP: Get some finishing ideas by visiting [BYOGuitar.com](http://www.byoguitar.com) and [BYO Guitar on Facebook](#)

(<http://www.byoguitar.com/gallery/index.html>)

especially if they have to be ordered, will allow expedite your guitar project.

We carry a full line of finishing products that give you the beautiful finish you are looking for, whether a clear natural finish or a bold, colorful finish. We also carry an instructional DVD made by Behlen that will give you step by step instructions to help you achieve the look you want for your custom guitar.

Introduction



These instructions assume you are familiar with the anatomy of a guitar. Refer to Figure 1 for many of the terms used in the assembly of your guitar.

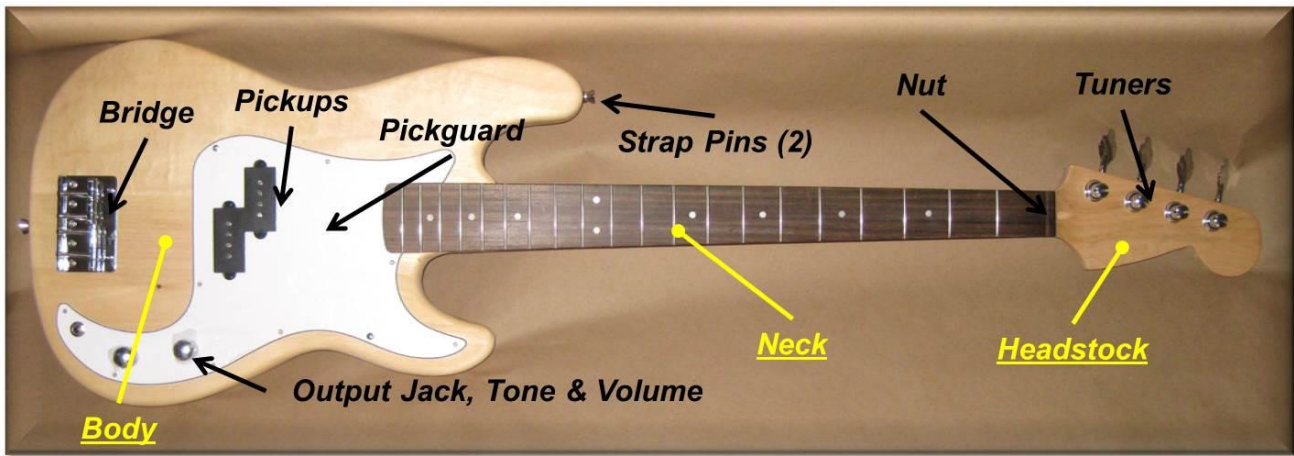





Fig 1 Major Components in Your P Bass Guitar Kit

1.1 Material Check List

In preparation for the building of your guitar, all required material should be checked both for type and quantity. Use the following check list to ensure all piece parts are included. If you customized your order (ex. different tuners), ensure that these parts are accounted for. Please contact BYOGuitar if there are any discrepancies.

P Bass Material List			
Item	Component	Quantity	Description
1		<ul style="list-style-type: none"> <input type="checkbox"/> 1 P Bass Body <input type="checkbox"/> 1 P Bass Neck <input type="checkbox"/> Miscellaneous materials (see below) 	BYO P Bass Guitar Kit
 TIP: use small interior packing box to inventory and organize piece parts			
2		<ul style="list-style-type: none"> <input type="checkbox"/> 1 Pickguard with Controls, pickups & jack 	P Bass Pickguard Assembly
3		<ul style="list-style-type: none"> <input type="checkbox"/> 4 mounting screws, 1 1/2" <input type="checkbox"/> 4 springs 	Pickguard mounting material



Introduction



4		<ul style="list-style-type: none"> □ 11 screws, 3/8" + spare 	<p>Mounting screws for Pickguard</p>
5		<ul style="list-style-type: none"> □ Bridge □ 7 mounting screws, 7/8" 	<p>Bridge components</p>
6		<ul style="list-style-type: none"> □ 1 mounting plate □ 1 plastic mounting gasket □ 4 screws, 1 3/4" 	<p>Neck Mounting material</p>
7		<ul style="list-style-type: none"> □ 4 Tuners □ 4 Tuner hole collars/inserts □ 16 screws, 3/8" 	<p>Tuners</p>
8		<ul style="list-style-type: none"> □ 2 Holders □ 2 plastic washers □ 2 screws, 1" 	<p>Strap Holder materials</p>
9		<ul style="list-style-type: none"> □ 1 String "Nut" □ 1 string tee w/mounting screw, 1/2" 	<p>String Nut & Guide</p>

Introduction



10		<ul style="list-style-type: none"> ☐ 4 strings 	Strings
11		<ul style="list-style-type: none"> ☐ Output Cable ☐ 2 Allen wrenches (for adjusting bridge, 1 for adjusting neck) 	Other

1.2 Additional tools/materials required:

Drill & drill bits	#1 & #2 Phillips screwdriver	Wood glue
Masking/painters tape	Finishing/painting material	Sand paper 220 & 320 grit
Guitar strap	Soap or candle	Feeler gauge
ruler		

Introduction



The remainder of the assembly instructions is divided into four sections:

Section 2 – Mockup & Fit check: in this section, all components will be checked for proper alignment and ensure that all holes have been drilled.

Section 3 – Finishing the Body and Neck: after fit check, the components are removed from the neck & body to allow the selected finish to be applied. This will allow you to customize your guitars' color(s). As the finishing will likely require several coats with sanding between each coat, ensure that the finish is completely dry.

Section 4 – Assembly: the final assembly is the next step - once the finish has been applied and completely dried. In this section, all of the components are installed, internal wiring connected and strings attached – your guitar will ready to go!

Section 5 – Setup: in this section, initial adjustments are made to your guitar, such as the height of the pickups.

Again, we thank you for your purchase of a BYO Guitar and we look forward to seeing pictures of your unique guitar! We also look forward to providing you with the guitar for your next project from our Custom Shop where you can select the wood for the body and neck as well as customizing all of the other components.

Let us know if your music, school, church or scouting organization would like to undertake a group project – BYO Guitar can supply multiple kits or custom guitars.

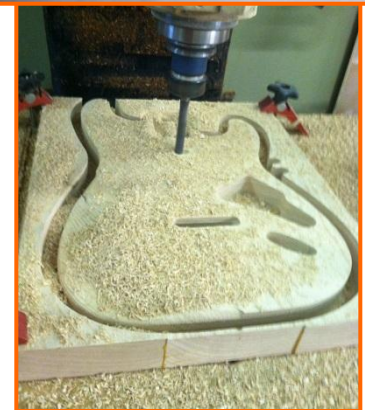

Some Ideas for Finishing Your Guitar and Examples of Our Custom Shop Products

Section 2 Contents

2 Mockup and Fit Check..... - 1 -

2.1 Check Guitar Body & Neck mounting holes..... - 1 -

2.1.1 Drilling the Mounting Holes in the Guitar Body..... - 1 -

2.2 Checking the Mounting Holes in the Neck..... - 2 -

2.2.1 Drilling Mounting Holes in the Neck - 2 -

2.3 Check the Neck to the Body Fit..... - 2 -

2.4 Fit check & alignment of the Pick Guard with Controls (item 2 on materials list)..... - 3 -

2.5 Fit check the Bridge..... - 3 -

2.6 Check Strap Pins..... - 3 -

2.7 Check Tuner Alignment..... - 4 -

2.8 String Tee Position - 4 -

2.9 Mockup and Fit Check complete! - 4 -

2 Mockup and Fit Check

The following steps will ensure that the base, neck, tuners, pickups, etc. are properly aligned and that all screw holes have been drilled.

 **TIP...use the large cover of the shipping box as a work area that can be easily stored when you're done working**

2.1 Check Guitar Body & Neck mounting holes

1. Check Neck pocket on the Body for pre-drilled (4) mounting holes (Figure 2.1);
2. Skip to 2.2 if the holes are pre-drilled.

2.1.1 Drilling the Mounting Holes in the Guitar Body

1. Use the neck plate as a template (#6 on material list) to locate the mounting holes in the neck pocket. The simplest way is to place the neck plate into the pocket and properly position it so it is centered in the pocket.
2. Mark the holes, center punch your marks.

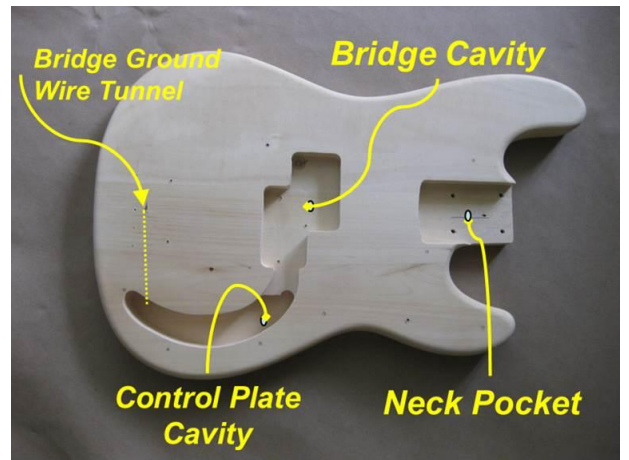

Figure 2.1 Body Locations

3. Drill the holes using a 3/16" drill bit.

2.2 Checking the Mounting Holes in the Neck

1. Check neck for pre-drilled (4) mounting holes.
2. Skip to 2.3 if the holes are pre-drilled.

2.2.1 Drilling Mounting Holes in the Neck

1. Place the neck in the pocket (...you should be able to fit the neck in the neck pocket by hand).
 - a. Carefully clamp the neck in place – frets damage easily.
 - b. Using the same drill bit you drilled the holes in the body, place the bit in the hole through the body and tap it a few times to make a mark on the neck.
2. Remove the neck from the body.
3. Determine the neck mounting hole depth.
 - a. Place one of the neck mounting screws through the neck plate and body into the neck pocket.
 - b. Measure the amount of the mounting screw that extends up into the neck pocket, and mark your drill bit.



TIP...a piece of masking tape around the drill bit works great as a depth indicator.

- c. **Double check the depth** by holding the marked drill bit to the side of the neck and be certain the drill won't go through the fingerboard.
4. Drill the holes in the neck with a 1/8" drill bit. **Make sure you don't drill through the fingerboard!**

2.3 Check the Neck to the Body Fit

Attach the neck so you can locate the pickguard. Use caution, the last thing you want to do is snap the screw off in the hole!



TIP...rubbing the threads of the screw on a bar of soap or candle will help prevent the wood from splitting

1. Insert the neck into the neck pocket and place the neck plate (with counter sunk holes facing out) & plastic base on the body.
2. Align the mounting holes in the neck and body
3. Fasten the 4 #7 x 1 3/8" screws, but do not final tighten them.

2.4 Fit check & alignment of the Pick Guard with Controls (item 2 on materials list)

1. Temporarily place the pickups into their positions in the pickguard – hold in place with tape. Place the Control Plate in the Body Control Plate Cavity (reference Figure 2.4), while inserting the pickguard around the neck – ensure that the wiring is in the cavity.

2. Carefully move the Pick Guard so that the Pick Guard contour is aligned with the contour of the Body.

3. If the pickguard holes are not pre-drilled, mark the holes and drill starter holes with 1/16 drill bit. Ensure all holes are pre-drilled.

4. Using 3/8" screws (item 4 on Material list), temporarily attach the pickguard in 2 places.

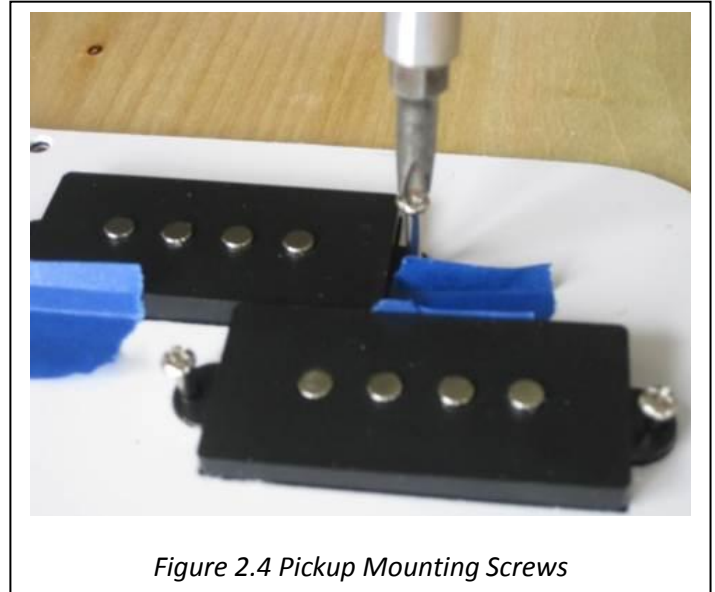

Figure 2.4 Pickup Mounting Screws

5. Using the pickup mounting screws (#3 on material list), carefully start each screw through the pickup into the body to a depth of approximately 1/4" – ensure that each screw is perpendicular to the body (Figure 2.4). The proper orientation of the pickups will be covered in the Assemble section.

6. Remove the Pickguard assembly.

2.5 Fit check the Bridge

1. Ensure that the tunnel for the Bridge ground wire is clear by inserting a small wire into the hole in the center of the top of the Body (reference Fig. 2.1) until it enters the Control Cavity.

2. Insert the Bridge (material list item #5) onto the Body (reference Figure 2.1), using the supplies 7 screws.

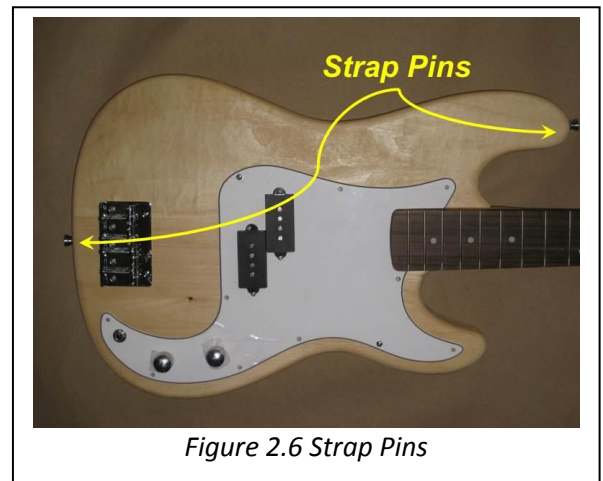

Figure 2.6 Strap Pins

2.6 Check Strap Pins

1. Check for pre-drilled holes for the Strap Pins (item 12 on the material list), reference Figure 2.6.
2. If the holes are pre-drilled, skip to 2.7.
 - a. Mark the rear Strap Pin hole so that it is centered on the Neck/Bridge and the forward Pin on the most forward point on the top of the Body (see Figure 2.6).

- b. Drill starter holes with a 1/16 drill bit.

2.7 Check Tuner Alignment

Each tuner assembly consists of the tuner and hole collar. The tuners are attached to the headstock with a small wood screws (#7 on list of materials).

1. Insert tuners (item #7 on Material List) into the Neck Headstock from the back. Insert hole collar the over the tuner shaft from the front. The collars will be glued in place during assembly.
2. Ensure that the Tuner shafts are perpendicular to the Headstock (Fig.2.8).
3. Check alignment of set screw holes (4) and tuner base.
4. If alignment is incorrect or holes are not drilled, mark hole locations and drill starter holes with 1/16 drill bit.
5. Repeat for the remaining 3 tuners.

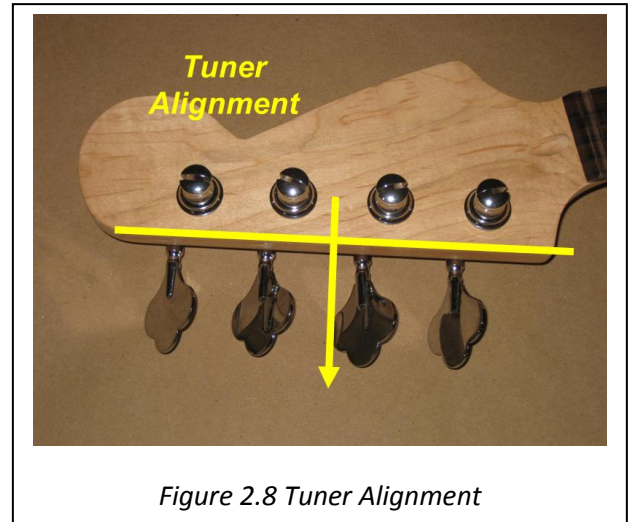

TIP... the holes may need to be widened with a peghead reamer or a round file. **DO NOT** widen the holes too much—the tuners should fit snug

2.8 String Tee Position

The hole required for the installation of String Tee will be made during the guitar final assembly.

2.9 Mockup and Fit Check complete!

Carefully disassemble the Mockup and move on to the next step: applying the finish to your guitar!

Section 3 Contents

3 Finish - 1 -

3.1 Finish Application Steps - 2 -

3.1.1 Solid Color finish: - 2 -

3.1.2 Pigmented Translucent, Gel stain or alcohol dye finish:..... - 2 -

3.1.3 Penetrating Stain or water based dye finish:..... - 2 -

3.2 Explanation of Sequence Steps:..... - 2 -

3.2.1 Sanding the Body and Neck - 2 -

3.2.2 Applying Grain Filler..... - 3 -

3.2.3 Applying Sanding Sealer - 3 -

3.2.4 Solid Color Primer - 3 -

3.2.5 Burst and Translucent finishes..... - 4 -

3.2.6 Clear Top coats..... - 4 -

3.2.7 Buff finish - 4 -

3 Finish

Before starting the finish make sure all holes are drilled for any remaining hardware (pickguard, jack plate, strap pins etc.). This section will cover the application of several finish types, including;

1. Solid color
2. Pigmented translucent, gel stain or alcohol dye
3. Penetrating stain or water based dye

The guitar body was sanded at the factory and coated with one coat of sand and sealer. To get a good finish, the body should be sanded with a series of sandpaper grits up to #320 grit. Apply a solid color finish, a pigmented translucent finish (Bursts, toners, Blonde, Butterscotch Blonde etc), a gel based stain or an alcohol based dye finish over the sanding sealer. If you plan on using a penetrating stain or water based dye, the sanding sealer must be removed.

How you proceed will depend on the finish you would like on your guitar.

The following paragraphs outline several finishing processes, starting with the sequence for a finish type (paragraph 3.1) followed by detailed explanation of each sequence step (paragraph 3.2).

3.1 Finish Application Steps

3.1.1 Solid Color finish:

1. Sand the body and neck
2. Apply grain filler if desired.
3. Apply 2 coats of sand and sealer
4. Sand to 320 grit
5. Apply primer
6. Sand the primer
7. Apply color coats
8. Apply clear top coats
9. Buff finish

3.1.2 Pigmented Translucent, Gel stain or alcohol dye finish:

1. Sand the body and neck
2. Apply grain filler if desired.
3. Apply 2 coats of sand and sealer
4. Sand to 320 grit
5. Apply stain or dye
6. Apply clear top coats
7. Buff finish

3.1.3 Penetrating Stain or water based dye finish:

1. Sand the body and neck to bare wood
2. Apply grain filler if desired.
3. Apply stain or dye
4. Apply 2 coats of sand and sealer
5. Sand to 320 grit
6. Apply clear top coats



TIP... re-open any of the screw holes in the body. Use a toothpick or small drill held between your fingers to clean out any filler in the holes.

7. Buff finish

3.2 Explanation of Sequence Steps:

3.2.1 Sanding the Body and Neck

1. Wear a NIOSH-approved respirator and ANSI-approved safety glasses when sanding wood!
2. Before starting the finish on the neck mask off the surface of the fingerboard.

Section 3 - Finishing Your Guitar



3. Use a flexible sanding block with #150 grit aluminum-oxide sanding paper to sand the guitar body until there is a consistent scratch pattern on the entire surface. Note: DO NOT round over the neck pocket or the body cavities. When hand sanding, always sand in the same direction as the wood grain.
4. Re-sand the entire guitar body and neck with #220 grit sanding paper and lightly round over the outside edges of the body.
5. Wipe the guitar body and neck with a damp cloth to “raise” the wood grain.
6. Wait until the wood is dry and re-sand with #220 grit sandpaper to sand the “raised” grain smooth.

(Note: On a maple fingerboard you can apply a clear finish to the entire neck and fingerboard. Apply several coats and remove buildup on the frets between coats. An easy way to remove the finish buildup on the frets is to take a nail and file a half round slot in the head about the same size as the frets. You can then use this to easily scrape any finish build up.

If the neck has a Rosewood or Ebony fingerboard, be sure to tape off the fingerboard before applying the finish. Behlen’s Fingerboard Oil is a great product for your fingerboard.)

3.2.2 Applying Grain Filler

Grain filler will fill in the grain and create flat surface. This is essential if you are trying to get a high gloss finish. Oil based grain filler is recommended. We recommend using Behlen PORE-O-PAC grain filler. For most finishes use natural colored filler. The dyes used in darker fillers may over time find their way through the color coat.

Apply the filler by wiping across the grain. You can use a course cloth or your fingers to wipe the grain in. After it has dried about ten to twenty minutes the excess can be removed with a cloth dampened with mineral spirits. After about an hour repeat the process and let dry overnight. If you have removed most of the excess with mineral spirits the remaining filler on the field of the wood can be sanded off (use #220 again) in a few minutes. It is also a good idea at this time to reopen any of the screw holes in the body. Use a toothpick or small drill held between your fingers to clean out any filler in the holes. The body is now ready for a sand and sealer coating.

3.2.3 Applying Sanding Sealer

Sand and sealer is used to give the final coat a level base. It is also helpful in filling scratches which are too deep to sand out. We recommend using Behlen Vinyl Sealer. This comes in aerosol cans and can easily be sprayed on.

3.2.4 Solid Color Primer

The last step before applying the color coats is to apply a white primer coat. We recommend using Ohio Valley Nitro Primer. The white background will also let you apply an opaque color coat with less paint. Spray on two coats. When dry you may notice that the surface feels rough. Sand off the roughness with

#320 dry and respray. Sand again. If the surface now appears smooth and all grain is opaqued you are ready for the color coat.

3.2.5 Burst and Translucent finishes

Bursts and Translucent finishes can be applied using aerosol cans of lacquer toner. Ohio Valley Nitro and Behlen have a full line of Nitrocellulose Lacquer Toners to achieve these finishes.

3.2.6 Clear Top coats

Apply several thin coats of the finish, following the manufacturer's instructions. Multiple thin coats usually produce a better quality finish than one heavy coat. Dry sand the entire body with #400 grit wet/dry sandpaper after at least three coats of finish have been applied. DO NOT sand through the finish, be careful on the edges. Use a tack cloth to remove sanding residue. Apply more finish, sanding between coats, until the finish is the desired thickness.

3.2.7 Buff finish

When the final coat has dried at least a week, preferably a month, remove the masking. Wet sand the finish using #600 grit wet/dry sandpaper with a sanding block, followed with #1000 grit wet/dry sandpaper. Use a clean, absorbent rag to remove excess water. Let the guitar dry completely, then use a tack cloth to remove all residue. Buff the finish by hand or with a buffer, starting with a medium polish and working up to a high gloss polish.

Note: If you use a buffing machine, be careful to avoid going through the finish, especially on the edges.

Section 4 Contents

4	Assembly	- 1 -
4.1	Attach the Neck to the Body	- 1 -
4.2	Installing Component Wiring & Installation.....	- 1 -
4.2.1	Preparation of pickups	- 2 -
4.2.2	Pickguard Wiring & Installation	- 3 -
4.2.3	Bridge & Frame Ground Wire Installation	- 3 -
4.3	Installing the Nut.....	- 3 -
4.4	Installing the Tuners.....	- 4 -
4.5	Install the Strings.....	- 4 -
4.6	Installing the Strap Pins.....	- 5 -
4.7	Installing the String Retainer.....	- 5 -

4 Assembly

After your finish has been applied and thoroughly dried, we can now assemble your guitar. In this section we will permanently install all of the components and the wiring for the bridge and pickguard.



TIP... use a blanket or large towel on your work area to protect your guitars' finish

4.1 Attach the Neck to the Body

1. Insert the Neck in the neck pocket. The Neck should fit snugly into the Body neck pocket – if there is more resistance than when the Neck and Body were fit-checked in section 2, check for finish material build up. Carefully sand the components with fine sandpaper as required.
2. Mount the Neck plate and plastic base with 1 3/4" screws (#6 on the material list – 4 ea.),



Reminder TIP...rubbing the threads of the screw on a bar of soap or candle will help prevent the wood from splitting

ensuring that the plate has the counter-sunk holes facing out.

3. Carefully tighten the screws – over tightening can damage the neck.

4.2 Installing Component Wiring & Installation

All of the electrical components are installed on the Pickguard assemble and pre-wired for installation with the exception of the Bridge ground wire. Figure 4.1 details the physical and interconnection of the Volume & Tone adjustments as well as the Pickups and Output jack. Refer to Figure 4.1 if there are any issues with the component wiring. (Note: wiring colors are typical and may vary).

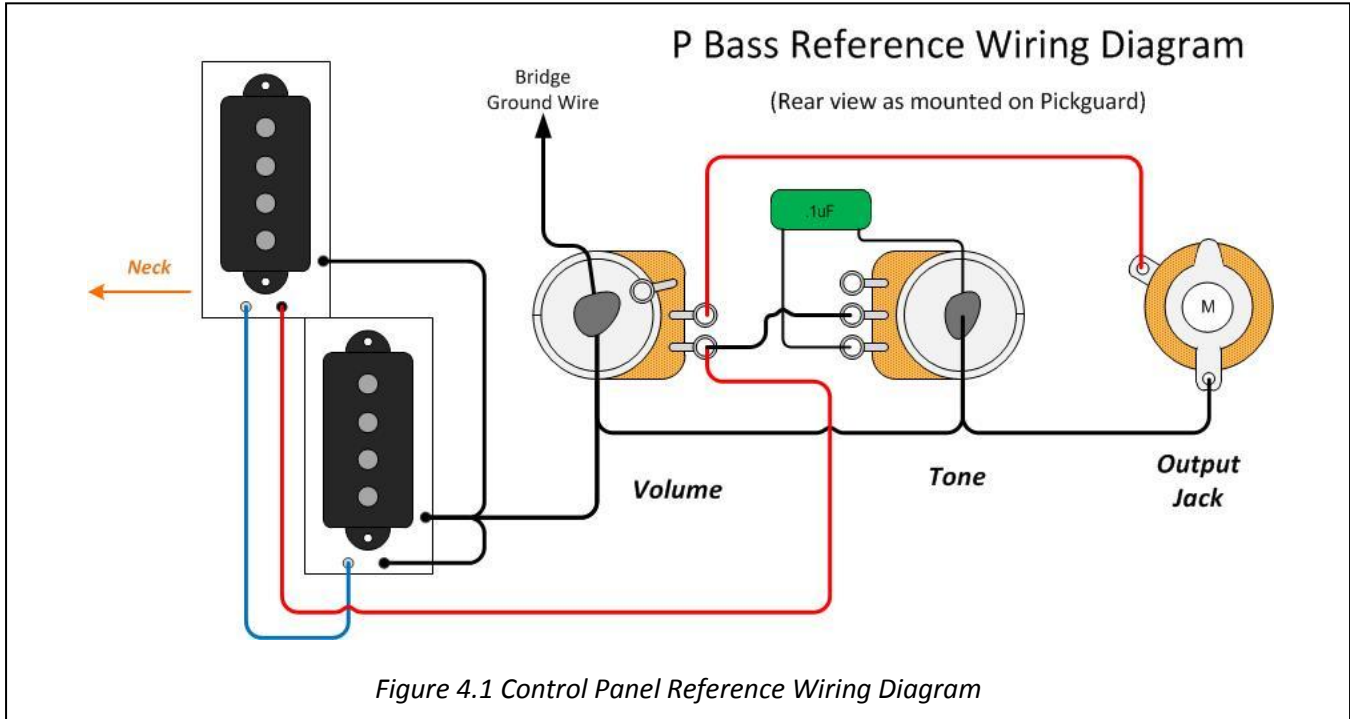

4.2.1 Preparation of pickups

1. Insert the pickups into the Pickguard (reference Fig. 4.2.1a) so that the pickup ground (black) is closest to the back of the Pickguard and the pickup with the signal wire (typically red) is closest to the neck cutout.

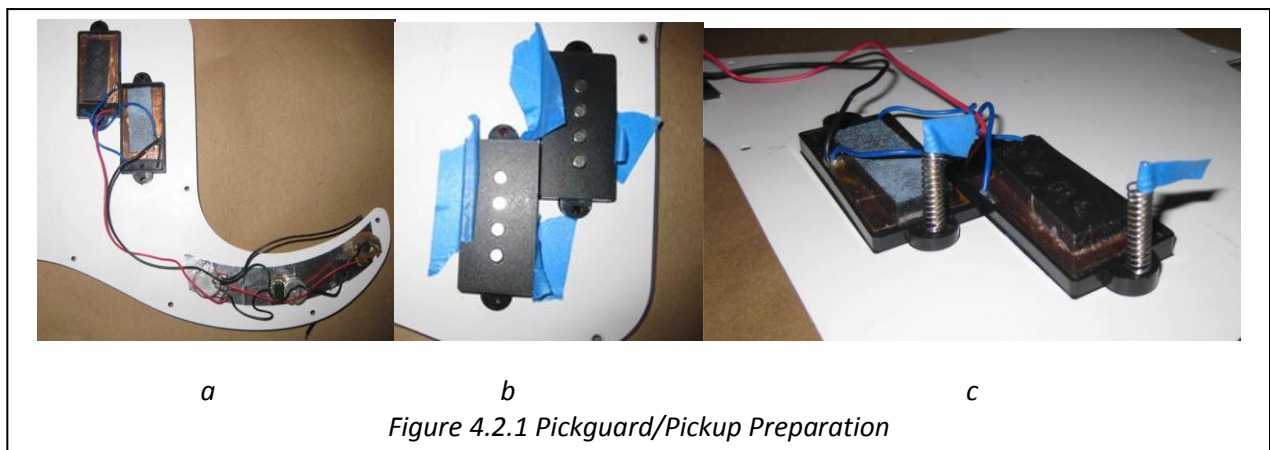

2. Temporarily attach the pickups to the top of the Pickguard with tape to hold them in place while installing the Pickguard, reference Fig. 4.2.1b.

Section 4 - Assembly



3. Insert Pickguard mounting screws & springs (#3 on the Material list – 4 ea.) into each pickup – temporarily hold in place with thin strips of tape as shown in Fig. 4.2.1c.

4.2.2 Pickguard Wiring & Installation

1. Take the black Bridge ground wire on the Pickguard assembly and feed it from the Control cavity to the hole underneath the Bridge (Fig.4.2.2).
2. Align the pickguard notch with Neck; gently slide the pickguard around the Neck while seating the Pickups and the Controls into their respective cavities. Ensure that all of the wires are in the cavities.
3. Align the pickguard with the pre-drilled holes and attached with supplied 3/8" screws.

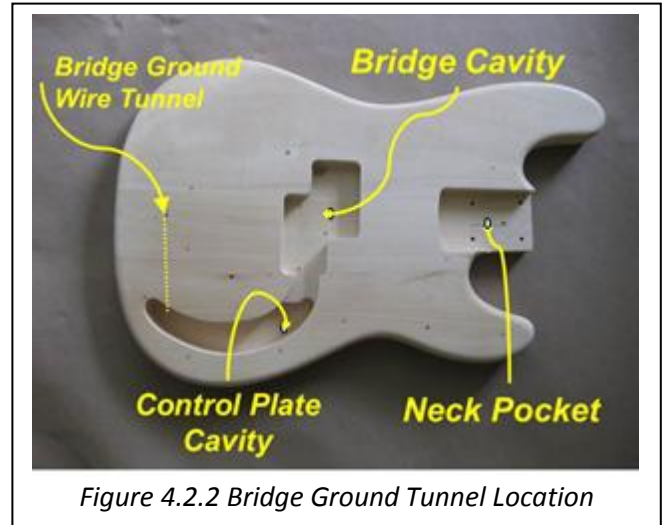

4. Screw in pickup adjustment screws (4 ea.) so that each pickup is approximately 1/8" above the pickguard. Ensure that the adjustment screws are vertical to the Body.

4.2.3 Bridge & Frame Ground Wire Installation

1. Strip approximately 1" of insulation from the Bridge ground wire. Push the wire into the tunnel so that the exposed wire remains: bend so that the wire is against the Body.
2. Install the Bridge with 3/4" screws (#5 on the material list – 7 ea.) ensuring that the bridge grounding wire is in contact with the Bridge.



4.3 Installing the Nut

The nut holds the strings at the headstock the correct distance above the frets. It is not necessary to cut the string notches in the nut that comes with this kit.

1. If necessary, use a chisel or razor blade to scrape any finish out of the nut slot. DO NOT remove any wood from the nut slot.
2. Spread a thin layer of wood glue in the nut slot and center the nut in the nut slot – let dry. If necessary, use a small clamp to ensure the nut is held in place.



TIP... wipe away the excess glue before it sets up - allow the glue to thoroughly dry

4.4 Installing the Tuners

Each tuner consists of the tuner and hole collar. The tuners are attached to the headstock with $\frac{3}{8}$ " wood screws (refer to Section 2.7).

1. Place a tuner into the headstock hole from the back.
2. Slide collar over the tuner shaft - secure the tuner to the guitar headstock with the supplied screws. Remove the protective film if necessary.
3. Repeat 1-3 on the remaining 3 tuners.
4. Remove the collars and place a small amount of wood glue on the inside of the tuner hole (a toothpick might make it easier) and the collar – reinsert the collar. Repeat on the remaining collars – let dry.

4.5 Install the Strings

Like most projects, there often several tricks that will make the assembly easier and your guitar better. Properly stringing your guitar is just one of those tricks. Please review the  following video:

How to restring your bass guitar with John Carruthers:

<https://www.youtube.com/watch?v=-8uBYlwMevA>

Although the video addresses restringing a guitar, the principles and techniques will help you string your guitar – as well as provide a visual for the stringing of your guitar.

In summary:

1. Carefully uncoil each of the strings (4), ensuring that the strings do not have a kink.
2. Adjust each tuner so that the capstan slot is parallel to the tuner shaft.
3. Run the largest diameter string (E) through the upper hole in the Bridge base plate, carefully seating the string ball against the base plate.
4. Cut the string approximately 5" beyond the upper tuner (first) tuner. Bend the wire 90 degrees at about $\frac{1}{2}$ " from the end and insert in the capstan hole of the first tuner.
5. Manually wind the string around the capstan in a clock wise direction and in a downward direction for 2 loops (check the video). Continue to wind the string on to the capstan using the tuner keeping tension on the string so that the winding will be tight. Continue tightening until the string is close to pitch. The Setup section will address fine tuning.
6. Repeat steps 1 through 5 on the remaining strings (A,D & G), using the largest diameter string during each repeat.

4.6 Installing the Strap Pins

Secure each strap pins (2) in the pre-drilled holes with the supplied screws (item #8 on the material list, 2ea, 1").

4.7 Installing the String Retainer

The String Retainer is used to ensure a steep angle of the D & G strings (relative to the nut) and is placed on the headstock between the D and G strings (the lower 2 strings as you would play the guitar).

1. Snug up the D&G strings. To protect the guitar finish while installing the String Tee, place a small piece of tape on the headstock approximately ½" behind the A string tuner (2nd tuner from the nut) and directly under the D&G strings.
2. Using a Spring Tee (item #13 on the material list), mark the headstock approximately ½" on the left side of the A string tuner, between the D & G strings, #3 &4.
3. Carefully drill 1/16" starter hole in the headstock.
4. Attach the String Tee to the headstock.

Also check out  :

[How to Install a Bass Guitar String Tree](https://www.youtube.com/watch?v=QVs27fHYhHA)

<https://www.youtube.com/watch?v=QVs27fHYhHA>



*Assembly of your Guitar
is now complete – let's
set it up!!*

Section 5 Contents:

5.1 [Setup](#) - 1 -

5.2 [Adjust the Guitar Neck: Truss Rod](#) - 2 -

 5.2.1 [Adjustment Check](#) - 2 -

 5.2.2 [Adjustment](#)..... - 2 -

5.3 [Bridge Saddle](#) - 2 -

 5.3.1 [Checking String Height](#)..... - 3 -

 5.3.2 [Bridge Saddle Adjustment](#)..... - 3 -

5.4 [Nut Action](#) - 3 -

 5.4.1 [Measurement](#)..... - 3 -

 5.4.2 [Nut Adjustment](#)..... - 3 -

5.5 [Pickup Height](#) - 4 -

 5.5.1 [Treble \(G string\) adjustment](#)..... - 4 -

 5.5.2 [Bass \(E string\) adjustment](#)..... - 4 -

5.6 [Intonation](#)..... - 4 -



5.7 [String Lubrication](#) - 5 -

5.8 [...Other Hints](#) - 5 -

5 Setup

In this section, we will address the initial setup for:

1. Adjusting the Neck (Truss Rod);
2. Adjusting the Bridge Saddle,
3. Adjusting the String Action (string height);
4. Adjusting the Pickup heights;
5. Adjusting the Intonation.

Reference...check out the following references that can be helpful in tuning your guitar:

- ✓ **tone generator for tuning:** http://www.get-tuned.com/online_guitar_tuner.php & <http://www.guitarforbeginners.com/onlinetuner.html>
- ✓ **downloadable “musical instrument tuner” from PerfectPitch (<http://www.nch.com.au/tuner/>) that will allow visualization of string adjustments**

These adjustments will provide preliminary settings from which you can fine tune the sounds to your individual playing style. As with previous sections, references are included for additional clarification of specific adjustments.

String up the guitar with your desired gauge of strings – check the tuning.

5.1 Adjust the Guitar Neck: Truss Rod

The first major procedure in the setup is adjusting the neck relief. Neck relief simply refers to how much the neck bows. The degree of bowing in the neck is a matter of personal preference and is correlated to your playing style.

5.1.1 Adjustment Check

First, check your tuning.

1. Put a capo at the first fret and press the sixth string at the last fret.
2. With a feeler gauge, check the gap between the bottom of the string and the top of the 8th fret—you should have about .015”.
3. If the height is correct, go to Step 5.2.



Reference: ...check out the following reference:



[Setting Up Your Bass Guitar: Adjusting The Truss Rod \(Step 1 of 4\) by John Caruthers](https://www.youtube.com/watch?v=te44eWXd9pc)

✓ <https://www.youtube.com/watch?v=te44eWXd9pc>

5.1.2 Adjustment

To adjust the neck relief, locate the truss rod at the neck/headstock junction. The truss rod is adjusted with the supplied Allen wrench. Tightening the truss rod adjustment bolt will cause the neck to warp backward (too much and the strings will buzz on the frets), and loosening it will cause it to bow forward (giving more relief.)

1. Sight down the edge of the fingerboard from behind the headstock, looking toward the body of the guitar.
 - a. If the neck is too concave (action too high), turn the truss rod nut clockwise to remove excess relief (only adjust $\frac{1}{4}$ turn at a time).
 - b. If the neck is too convex (strings too close to the fingerboard), turn the truss rod nut counter-clockwise to allow the string tension to pull more relief into the neck.
2. Check tuning, then re-check the gap with the feeler gauge and re-adjust as needed.



TIP: ... do the neck adjustment in a series of intermediate steps and re-tune your guitar before each step – different tension on the strings changes the adjustment of the neck

5.2 Bridge Saddle

This will adjust the height of the strings over the 12th fret. Minor adjustments are



Reference...check out the following reference:



<https://www.youtube.com/watch?v=c2DIwxSIPAO>
[Setting Up Your Bass Guitar: Bridge Action Height Adjustment \(Step 2 of 4\) by John Caruthers](#)

Section 5 - Setup



made by raising or lowering the bridge saddles. This adjustment is a matter of personal preference. There should be a gradual decrease in height from the E string to the G string. Table 5.4 should be used as a reference for adjusting the Bridge saddles.

5.2.1 Checking String Height

Using a calibrated metal ruler, measure the height of the string above the 12th Fret as shown in Figure 5.2.1. Check the measured height against the desired height in Table 5.2.

5.2.2 Bridge Saddle Adjustment

1. If incorrect, adjust the string saddle height clock wise to increase the measured distance or counterclockwise to decrease the measured distance. There are 2 adjustments on each saddle that should be adjusted simultaneously so that the saddle remains level.
2. Repeat on the next string until all strings have been adjusted.

Bridge Saddle Adjustments	
String	Height @ 12 th Fret
E (top string)	4/32"
A	3/32" (+)
D	3/64" (+)
G	3/64"

Table 5.2 Bridge Adjustment

5.3 Nut Action

Setting the string action that is right for you starts at the nut. The slots should already be close, but you might want to make some adjustments. The adjustment of the nut height requires special files and can be performed at a future date. If you are unsure how this action will impact your specific playing style, we suggest that you measure and record the height for all strings in Table 5.3. Should you decide to make this adjustment in the future, you will know which strings need to be adjusted and by how much.

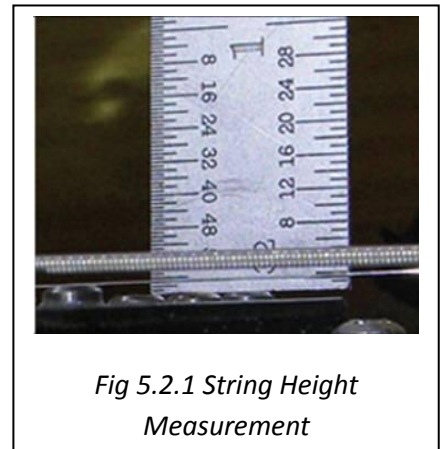

Fig 5.2.1 String Height Measurement

5.3.1 Measurement

1. Using a .022 feeler gauge, measure & record the space between the first fret and the bottom E string – the gauge should be a snug fit if spacing is correct.
2. Repeat on A, D & G strings.



Reference...check out the following reference:



<https://www.youtube.com/watch?v=cI9Y9MsmnEc>

Setting Up Your Bass Guitar: Nut Action Height Adjustment
(Step 3 of 4): by John Caruuthers

5.3.2 Nut Adjustment

If the gap is wider than .022", the slot needs to be deepened.

1. Detune the tuner for the string you are working on so that it can be removed from the nut.

String	Height @1 st Fret
E	
A	
G	
D	

Section 5 - Setup



2. Using a small file or round needle file, carefully deepen the nut slot. Make sure when you deepen the nut slot, the file is angled down toward the headstock. This will ensure the string sits on the edge of the nut closest to the fretboard.
3. The slot adjustment will take several iterations to ensure the depth is correct. Replace the string in the nut, retune using the tuner and check the spacing.
4. Repeat steps 1-3 until the depth is correct.
5. Repeat steps 1-4 for the remaining 3 strings.

5.4 Pickup Height

There are two adjustments that are required for the P Bass guitar: treble adjustment of the G string, and bass adjustment of the E string. Again the final adjustment height is your personal choice – the following adjustments will be a place to start. Determining the best combination of tone and volume will require some experimentation.

5.4.1 Treble (G string) adjustment

1. Measure the distance from the bottom of the G string (furthest from the top of the guitar) to the top of the pickup closest to the Bridge: correct measurement is 1/8".
2. If correct, go to step 5.5.2
3. Adjust the 2 screws on the G string pickup for the 1/8" measurement. Push on the pickup to ensure that the pickup springs are free.

5.4.2 Bass (E string) adjustment

4. Measure the distance from the bottom of the E string (closest to the top of the guitar) to the top of the pickup closest to the Neck: correct measurement is 1/8".
5. If correct, go to step 5.6.
6. Adjust the 2 screws on the E string pickup for the 1/8" measurement. Push on the pickup to ensure that the pickup springs are free.

5.5 Intonation

Intonation adjustments should be made after all of the above have been accomplished. Again, intonation is a personal choice and we suggest reviewing the adjacent reference before proceeding.

1. Turn the volume & tone controls to maximum.



Reference...check out the following



adjustment:

<https://www.youtube.com/watch?v=FC30nJgIAJM>

Setting Up Your Bass Guitar: Intonation Adjustment (Step 4 of 4) Intonation: by John Caruuthers

Section 5 - Setup



2. Check tuning. Check each string at the 12th fret, harmonic to fretted note (make sure you are depressing the string evenly to the fret, not the fingerboard).
3. If sharp, lengthen the string by adjusting the saddle back. If flat, shorten the string by moving the saddle forward.

5.6 String Lubrication

Lubricate the contact points of a string's travel to ensure tuning stability and reduce string breakage.

Lubricate:

1. String/saddle contact points on the Bridge with a light machine oil (...such as "3-in-1 oil" because it contains anti-rust and anti-corrosive properties) every time you change strings.
2. String trees should also be lubricated; a small amount of lip balm applied with a toothpick works well.

5.7 ...Other Hints

There are a few other things that you can do to optimize your tuning stability:

1. Each time you play your guitar, before you do your final tuning, play for a few minutes to allow the strings to warm up. Metal expands when warm and contracts when cool. After you've played a few riffs, you can then do your final tuning;
2. Wipe the strings, neck and bridge with a lint-free cloth after playing;
3. When transporting or storing your guitar, even for short periods, avoid leaving it anyplace you wouldn't feel comfortable yourself.

Remember, guitars are tempered instruments! Re-tune, play and make further adjustments as needed.

We hope you have enjoyed building your guitar! If you have any questions along the way please email us at sales@BYOGuitar.com.

....for all of your Guitar needs!!!!



byo guitar
build your own

*Custom Shop Products:
Made in the U.S.A.*

