

# *LP Standard Kit Assembly Instructions*



Revision (B) April 13, 2017

 Find us on  
Facebook

[www.byoguitar.com](http://www.byoguitar.com)



California requires the following notice:

### **WARNING**

*Some dust created by power sanding, sawing, grinding, drilling, and other construction activities contains chemicals known to the State of California to cause cancer, birth defects or other reproductive harm.*

*Some examples of these chemicals are:*

- *Lead from lead-based paints.*
- *Crystalline silica from bricks, cement, and other masonry products.*
- *Arsenic and chromium from chemically treated lumber.*

*Your risk from these exposures varies, depending on how often you do this type of work. To reduce your exposure to these chemicals: work in a well ventilated area, and work with approved safety equipment, such as those dust masks that are specially designed to filter out microscopic particles.*

### **Warning**

*Always wear safety glasses or goggles when operating equipment. Everyday glasses or reading glasses are not safety glasses. Be certain the safety glasses you wear meet the appropriate standards of the American National Standards Institute (ANSI). Because there are various ways to cut and join wood, you can make substitutions for the methods stated in this manual. We try to suggest the easiest methods possible. However, only you know your skills with each piece of machinery. Never compromise your safety by using a cutting method with which you are not comfortable. Instead, find an alternative approach that will yield the same result.*

### **Warning**

*These instructions assume that you are familiar with the safe operation and use of woodworking machinery and woodworking tools, and understand the techniques used to assemble this project. If you do not qualify for both of these criteria, STOP building this project for your own safety. Read and understand the owner's manual for the machinery you intend to use, take a woodworking class or visit your local library for more information. Woodworking machinery and tools are inherently dangerous because they use sharp edges that can and will cause serious personal injury including amputation and death. Do not underestimate the ability of these tools and machinery to cause injury. Never operate any tool without all guards in place and always wear approved safety glasses. For your own safety, please heed this warning.*

## Contents

Contents..... - 2 -

1 Introduction ..... - 2 -

    1.1 Material Check List..... - 3 -

    1.2 Additional tools/materials required: ..... - 5 -

## 1 Introduction

Thank you for purchasing a BYOGuitar.com guitar kit. This kit includes everything you need to build a complete custom guitar. In addition to the construction of your guitar, you will need to consider the finish – natural, solid color and possibly a design that will make your guitar unique. We suggest you do some research to determine your finish preferences. Procuring the required finishing materials,



**TIP:** Get some finishing ideas by visiting [BYOGuitar.com](http://www.byoguitar.com) and [BYO Guitar on Facebook](#) (<http://www.byoguitar.com/gallery/index.html>)

especially if they have to be ordered, will allow expedite your guitar project.

We carry a full line of finishing products that give you the beautiful finish you are looking for, whether a clear natural finish or a bold, colorful finish. We also carry an instructional DVD made by Behlen that will give you step by step instructions to help you achieve the look you want for your custom guitar.

These instructions assume you are familiar with the anatomy of a guitar. Refer to Figure 1 for many of the terms used in the assembly of your guitar.

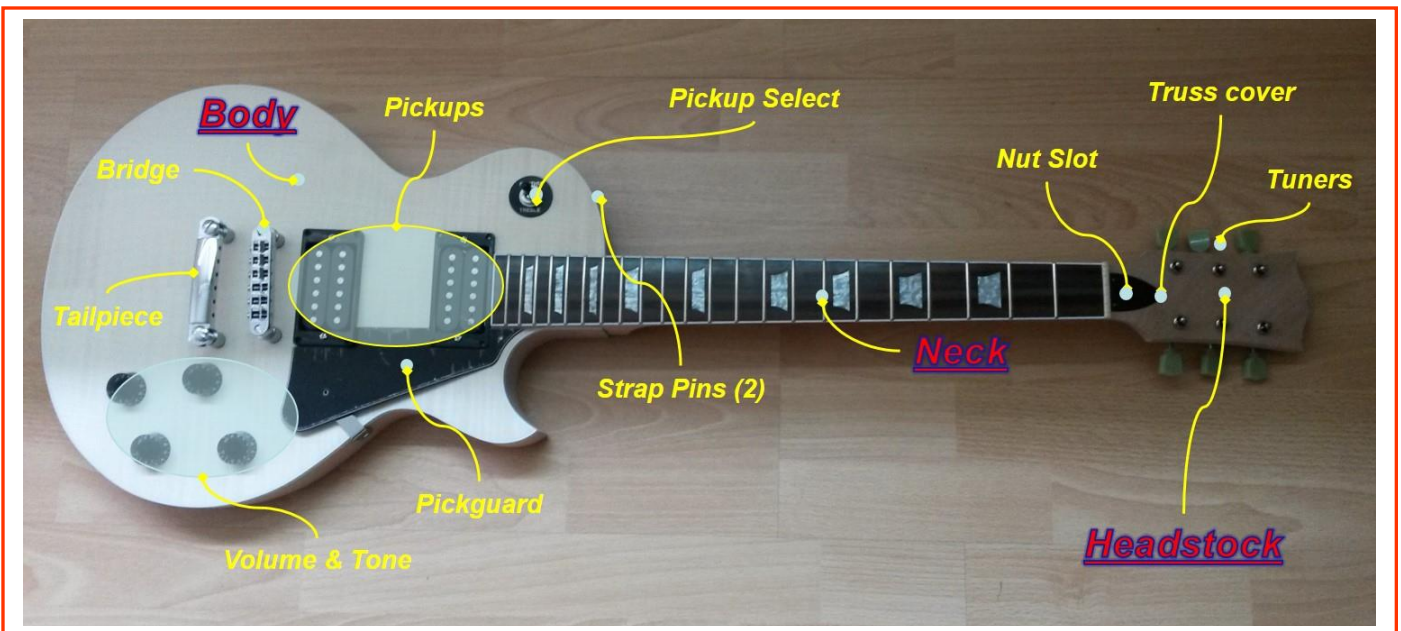

### 1.1 Material Check List

In preparation for the building of your guitar, all required material should be checked both for type and quantity. Use the following check list to ensure all piece parts are included. If you customized your order (ex. different tuners), ensure that these parts are accounted for. Please contact BYOGuitar if there are any discrepancies.

LP Standard Material List			
Item	Component	Quantity	Description
1		<ul style="list-style-type: none"> <li><input type="checkbox"/> 1 LP Std. Body</li> <li><input type="checkbox"/> 1 LP Std. Neck</li> <li><input type="checkbox"/> Miscellaneous materials (see below)</li> </ul>	BYO LP Std. Guitar Kit
<b>TIP: use small interior packing box to inventory and organize piece parts</b>			
2		<input type="checkbox"/> 1	LP Std. Pickguard
3		<ul style="list-style-type: none"> <li><input type="checkbox"/> 2 black pickups</li> <li><input type="checkbox"/> 8 mounting screws</li> </ul>	Pickups
4		<input type="checkbox"/> 9 screws <sup>3/8"</sup>	Mounting screws for Pickguard & Back Plates
5		<ul style="list-style-type: none"> <li><input type="checkbox"/> Tune-o-matic bridge</li> <li><input type="checkbox"/> 2 posts</li> </ul>	LP Std. tailpiece

## Introduction



6		<ul style="list-style-type: none"> <li>☐ 1 harness w/ 4 potentiometers</li> </ul>	LP Std. Wiring harness
7		<ul style="list-style-type: none"> <li>☐ 1 bridge</li> <li>☐ 2 posts</li> </ul>	Bridge assembly
8		<ul style="list-style-type: none"> <li>☐ 2 tone</li> <li>☐ 2 volume</li> </ul>	LP Std. knobs
9		<ul style="list-style-type: none"> <li>☐ 3 Tuning Pegs, upper</li> <li>☐ 3 Tuning pegs, lower</li> <li>☐ 6 Washers</li> <li>☐ 6 Inserts, spacers</li> <li>☐ 12 screws, 1/2"</li> </ul>	Tuning Peg materials
10		<ul style="list-style-type: none"> <li>☐ 1 plate, switch</li> <li>☐ 1 plate, audio control</li> </ul>	Electronics cover
11		<ul style="list-style-type: none"> <li>☐ Jack w/plate</li> <li>☐ 4 mounting screws</li> </ul>	Output Jack assembly <i>(note: jack is prewired to harness)</i>
12		<ul style="list-style-type: none"> <li>☐ 2 Holders</li> <li>☐ 2 plastic washers</li> <li>☐ 2 screws, 1"</li> </ul>	Strap Holder materials

## Introduction

13		<ul style="list-style-type: none"> <li>☐ 1 bracket</li> <li>☐ Nut &amp; bolt</li> </ul>	Pickguard bracket
14		<ul style="list-style-type: none"> <li>☐ 6 strings</li> </ul>	Strings
15		<ul style="list-style-type: none"> <li>☐ Output Cable</li> <li>☐ 2 Allen wrenches</li> </ul>	Other
16		<ul style="list-style-type: none"> <li>☐ Pickup select</li> </ul>	Switch
17		<ul style="list-style-type: none"> <li>☐ Truss cover</li> </ul>	Cover

### 1.2 Additional tools/materials required:

Drill & drill bits	#1 & #2 Phillips screwdriver	Soldering iron/solder
Masking/painters tape	Finishing/painting material	Sand paper 220 & 320 grit
Guitar strap	Soap or candle	Feeler gauge
ruler	Wood glue	Clamps
Wrap (8") or straw	String or fishing line (36")	

## Introduction



The remainder of the assembly instructions is divided into four sections:

**Section 2 – Mockup & Fit check:** in this section, all components will be checked for proper alignment and ensure that all holes have been drilled.

**Section 3 – Finishing the Body and Neck:** after fit check, the components are removed from the neck & body to allow the selected finish to be applied. This will allow you to customize your guitars' color(s). As the finishing will likely require several coats with sanding between each coat, ensure that the finish is completely dry.

**Section 4 – Assembly:** the final assembly is the next step - once the finish has been applied and completely dried. In this section, all of the components are installed, internal wiring connected and strings attached – your guitar will ready to go!

**Section 5 – Setup:** in this section, initial adjustments are made to your guitar, such as the height of the pickups.

Again, we thank you for your purchase of a BYO Guitar and we look forward to seeing pictures of your unique guitar! We also look forward to providing you with the guitar for your next project from our Custom Shop where you can select the wood for the body and neck as well as customizing all of the other components.

Let us know if your music, school, church or scouting organization would like to undertake a group project – BYO Guitar can supply multiple kits or custom guitars.

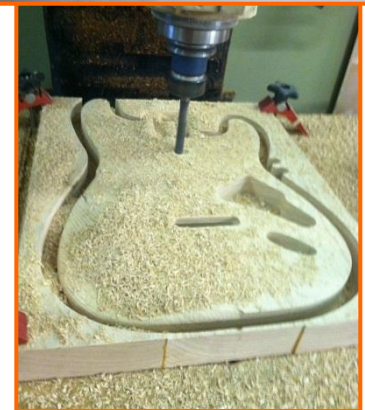

*Some Ideas for Finishing Your Guitar and Examples of Our Custom Shop Products*

## Section 2 Contents

2	Mockup and Fit Check (Figure 2.0)	- 1 -
2.1	Fit check the Neck to the Body	- 1 -
2.2	Checking the Pickups, Pick guard and Truss access cover	- 1 -
2.2.1	Mounting of Pickups & Pick guard (reference Figure 2.2.1-1)	- 1 -
2.2.2	Truss access cover (Figure 2.2.2-1)	- 3 -
2.3	Checking Electrical wiring and components	- 3 -
2.4	Check Bridge assembly (Figure 2.4-1)	- 3 -
2.	Partially insert (approximately 1/8") the "stop tail piece" inserts & posts into the holes furthest from the neck – install (slide) the stop piece over the posts.	- 3 -
2.5	Check for Bridge Ground Tunnel	- 3 -
2.5.1	Drilling the Bridge Ground Tunnel	- 4 -
2.6	Miscellaneous Fit Checks	- 4 -
2.6.1	Fit check of the back cavity Covers (Fig 2.6.1-1)	- 4 -
2.6.2	Output Jack	- 4 -
2.6.3	Check Strap Pins (Figure 2.6.3)	- 4 -
2.6.4	Check Tuner Alignment (Figure 2.6.4)	- 5 -

## 2. Mockup and Fit Check (Figure 2.0)

The following steps will ensure that the base, neck, tuners, pickups, etc. are properly aligned, wired and that all screw holes have been drilled.

### 2.1 Fit check the Neck to the Body

Gently insert the Neck into the neck cavity on the Body – the fit should be snug to ensure proper alignment when these pieces are glued during assembly. If the pieces will not fit or are very tight, lightly sand the neck. If the neck is loose, please call BYO Guitar to resolve the issue. The Neck and Body will be glued together in Section 4, Assembly.

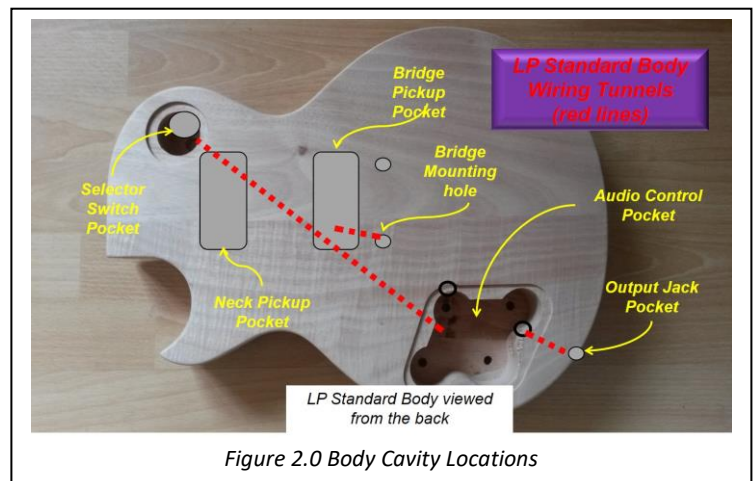

### 2.2 Checking the Pickups, Pick guard and Truss access cover

#### 2.2.1 Mounting of Pickups & Pick guard (reference Figure 2.2.1-1)

Locate the following parts in your kit:



## Section 2 – Mockup & Fit Check

<u>Item</u>	<u>Material List</u>	<u>Detail</u>
Pickguard	2	
Pickups with screws (8 total)	3	Thin taper: Neck pickup Thick taper: Body pickup
Pickguard bracket	13	
Neck		

During this step, the combination of the Pickups, Pickguard and Neck will be aligned so ensure the correct fitting. Note that the Body is contoured where the Pickups are mounted and should be considered when marking hole positions.

1. Position the Bridge pickup (item #3 on parts list, with the thicker taper) in the Bridge cavity, temporarily running the wire through the tunnel to the Audio cavity;

2. Position the Neck pickup (item #3 on parts list, with the thin taper) in the neck cavity, temporarily running the wire through the tunnel to the Audio pocket;

3. Attach the Pickguard bracket to the Pickguard (enlarge hole as necessary);

4. Mount the pick guard so that the Pickups are snug in the Pickup notches and matches the contour of the body while aligning the

Pickups to be centered in the pockets – insert the Neck to ensure complete alignment. This will require a few times before the alignment is optimized;

5. Mark 1 lower hole in each of the Pickups – drill starter holes and insert 2 mounting screws.
- Check the overall alignment of all components;
  - Realign as necessary;
  - When the alignment is correct, pre-drill all remaining holes: 8 for the Pickups, 1 for the Pickguard and 1 for the Pickguard bracket;

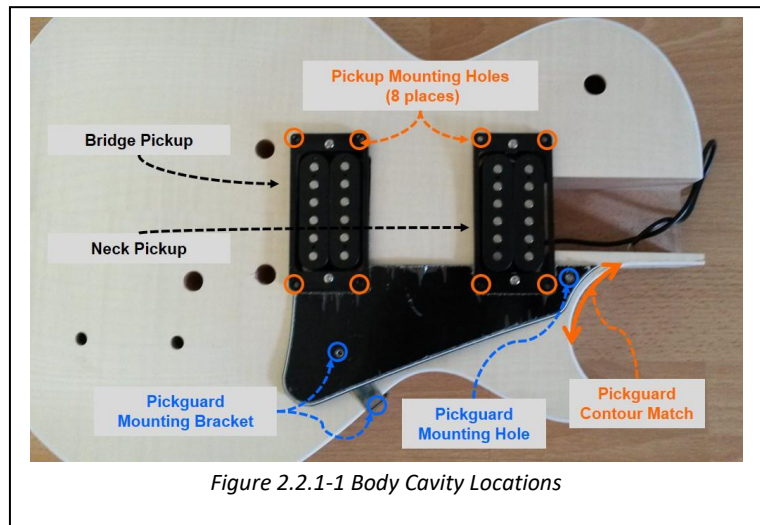

Figure 2.2.1-1 Body Cavity Locations

## Section 2 – Mockup & Fit Check



d. As a final check, mount all components.

### 2.2.2 Truss access cover (Figure 2.2.2)

1. Align the plastic cover (Item # 17 on parts list) with the Truss access hole.
2. Mark and pre-drill the 3 holes.

### 2.3 Checking Electrical wiring and components

Your LP Standard guitar kit comes with a wiring harness that is ready for installation during assembly of your guitar (Section 4). Check the harness to ensure that all wiring remains solidly soldered to each component – re-solder as required (...if necessary, check Figure 4.2 for wiring color codes).

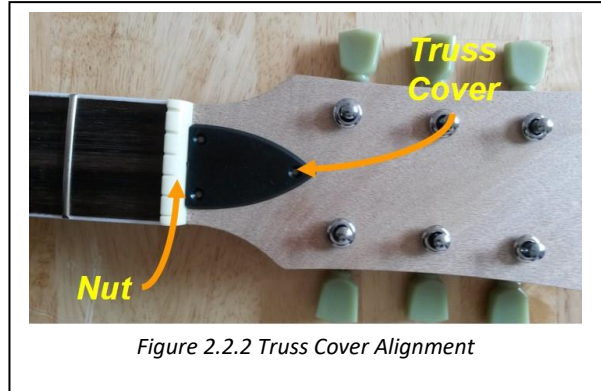

Figure 2.2.2 Truss Cover Alignment

### 2.4 Check Bridge assembly (Figure 2.4-1)

The LP Standard bridge assembly consists of a “Tune-o-matic” bridge and a “stop tail piece”, each with 2 posts (Items # 5 & 7 on parts list). Each post is press fit into the body at assembly - hole alignment will be validated during this step.

1. Partially insert (approximately 1/8”) the “tune-o-matic” inserts & posts into the holes closest to the neck – install bridge over the posts.
2. Partially insert (approximately 1/8”) the “stop tail piece” inserts & posts into the holes furthest from the neck – install (slide) the stop piece over the posts.

Please call BYOGuitar if there are any issues with steps 1-2 above.

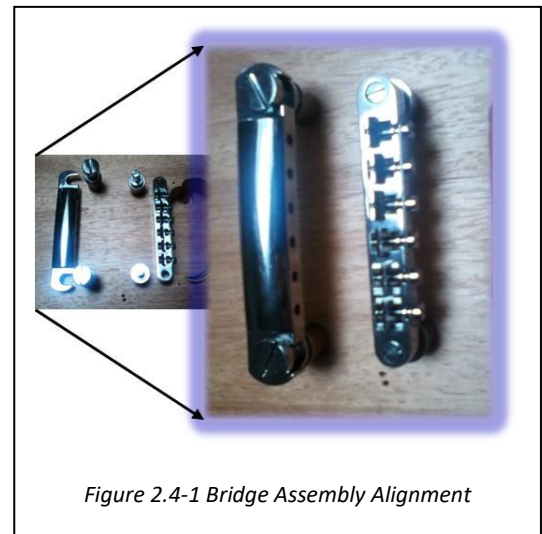

Figure 2.4-1 Bridge Assembly Alignment

### 2.5 Check for Bridge Ground Tunnel

In order to minimize audio hum and pickup, the electrical components are grounded together. This check ensures that there is a tunnel for routing the Bridge ground wire to the Bridge mounts. Reference Figure 2.0 for the layout of electrical component and wiring – specifically the Bridge Ground wire tunnel, as shown in Figure 2.5 where a tunnel connects the Bridge pickup cavity to the Bridge mounting hole. Proceed to Paragraph 2.6 if there is a tunnel.

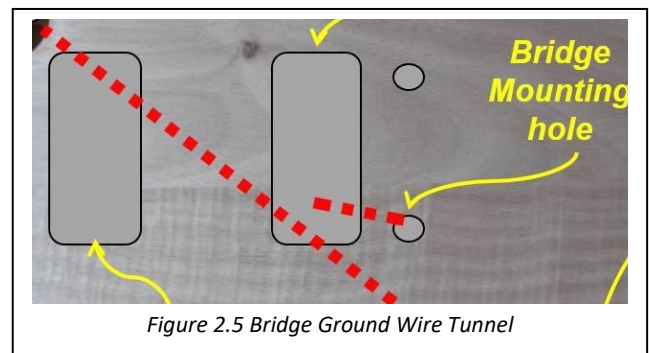

Figure 2.5 Bridge Ground Wire Tunnel

### 2.5.1 Drilling the Bridge Ground Tunnel

As shown in Figure 2.5.1-1, place the Body face up and locate the lower Bridge Mount hole. **Note:** use extreme **caution when drilling** the tunnel as the drill can come in contact with the Body causing damage. Placing material against the drill bit (white strip in Figure 2.5.1-1) will help protect the Body.

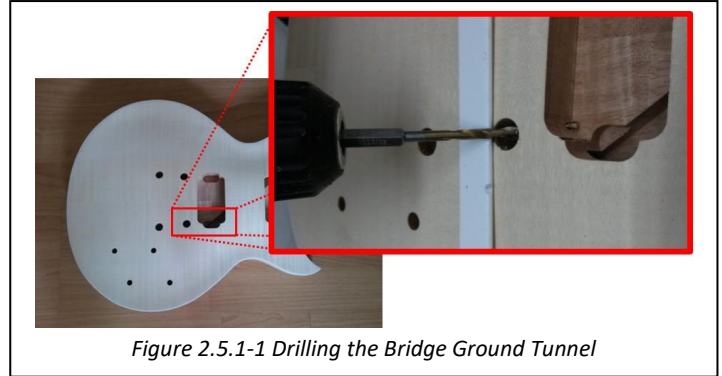

Figure 2.5.1-1 Drilling the Bridge Ground Tunnel

1. Use a 3/32" drill, pre-drill a starter hole for the tunnel approximately 1/4" deep in the mounting hole and at 45 degrees;
2. Use a 5/32" drill, at 45 degrees, to complete the drilling of the tunnel so that tunnel enters the Bridge Pickup cavity;
3. Run a small piece of wire through the tunnel to ensure there is no blockage.

## 2.6 Miscellaneous Fit Checks

### 2.6.1 Fit check of the back cavity Covers (Fig 2.6.1)

Insert the black covers (item #10 on material list) into the back cavities of the body – the cover typically has a plastic protective film to avoid scratching. Pre-drill the 7 holes for assembly mounting.



Figure 2.6.1 Back Body Cover Alignment

### 2.6.2 Output Jack

Check for pre-drilled holes (4) for the Output Jack (material list #11), reference Figure 2.0.

1. If the holes are pre-drilled, skip 2.6.3.
2. Align the Output Jack plate (the jack is part of the pre-wired harness) over Jack Cavity (Fig 2.0).
3. Mark the holes and drill starter holes with 1/16 drill bit.

### 2.6.3 Check Strap Pins (Figure 2.6.3)

Check for pre-drilled holes for the Strap Pins (item 12 on the material list), reference Figure 2.0. If the holes are pre-drilled, skip to 2.6.4.

1. Mark the rear Strap Pin hole so that it is aligned with the center of the neck & pickups (Figure 2.6.3), and the forward Pin approximately 1" above the Neck cavity;
2. Drill starter holes with a 1/16 drill bit.

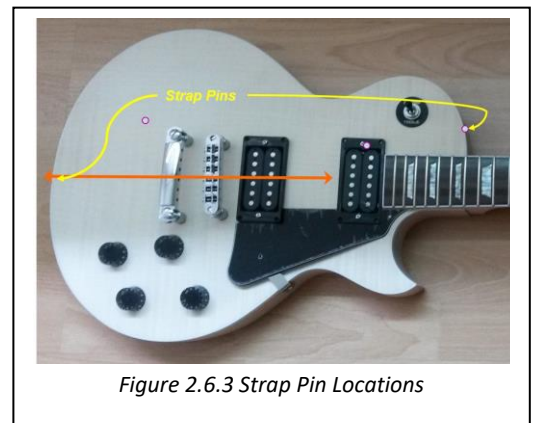

Figure 2.6.3 Strap Pin Locations

## Section 2 – Mockup & Fit Check



### 2.6.4 Check Tuner Alignment (Figure 2.6.4)

Each tuner consists of the tuner and a collar bushing. The tuners are attached to the headstock with a small wood screws.

1. There are two different types of tuners (item #9 on the Material list): 3 that are mounted on the top of the Neck and 3 on the bottom of the Neck. When mounted correctly, the adjustment knob should be closer to the end of the Neck than the shaft;
2. Partially insert the shaft collar into the Neck hole (final installation is covered in Section 4);
3. Insert the tuner, aligning the Tuner knob shaft to be perpendicular to the Neck – mark hole locations and drill starter holes with 1/16 drill bit – use **caution** when drilling as the headstock is thin;
4. Repeat steps 2 & 3 for the remaining Tuners.

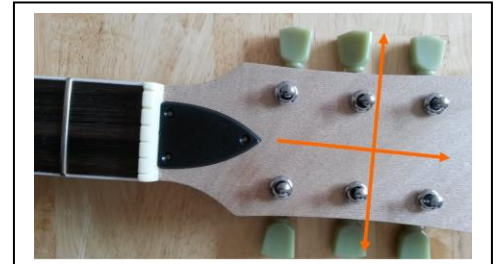

Figure 2.6.4 Tuner Alignment



**CAUTION:**  
*The headstock is thin – do not drill through!!*

Carefully disassemble the Mockup and move on to the next step: applying the finish to your guitar!

## Section 3 Contents

- 3 [Finish](#) ..... - 1 -
- 3.1 [Finish Application Steps](#) ..... - 2 -
- 3.1.1 [Solid Color finish:](#) ..... - 2 -
- 3.1.2 [Pigmented Translucent, Gel stain or alcohol dye finish:](#)..... - 2 -
- 3.1.3 [Penetrating Stain or water based dye finish:](#)..... - 2 -
- 3.2 [Explanation of Sequence Steps:](#)..... - 2 -
- 3.2.1 [Sanding the Body and Neck](#) ..... - 2 -
- 3.2.2 [Applying Grain Filler](#)..... - 3 -
- 3.2.3 [Applying Sanding Sealer](#)..... - 3 -
- 3.2.4 [Solid Color Primer](#) ..... - 3 -
- 3.2.5 [Burst and Translucent finishes](#)..... - 4 -
- 3.2.6 [Clear Top coats](#)..... - 4 -
- 3.2.7 [Buff finish](#) ..... - 4 -

## 3 Finish

Before starting the finish make sure all holes are drilled for any remaining hardware (pickguard, jack plate, strap pins etc). This section will cover the application of several finish types, including;

1. Solid color
2. Pigmented translucent, gel stain or alcohol dye
3. Penetrating stain or water based dye

The guitar body was sanded at the factory and coated with one coat of sand and sealer. To get a good finish, the body should be sanded with a series of sandpaper grits up to #320 grit. Apply a solid color finish, a pigmented translucent finish (Bursts, toners, Blonde, Butterscotch Blonde etc), a gel based stain or an alcohol based dye finish over the sanding sealer. If you plan on using a penetrating stain or water based dye, the sanding sealer must be removed.

How you proceed will depend on the finish you would like on your guitar.

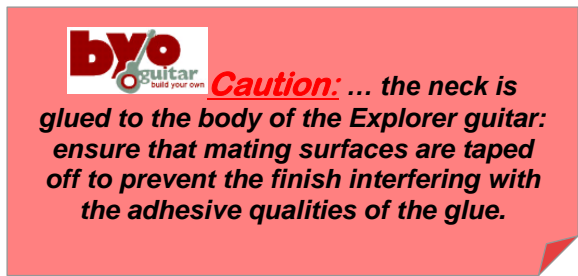

**byo guitar** *build your own* **Caution:** ... the neck is glued to the body of the Explorer guitar: ensure that mating surfaces are taped off to prevent the finish interfering with the adhesive qualities of the glue.

The following paragraphs outline several finishing processes, starting with the sequence for a finish type (paragraph 3.1) followed by detailed explanation of each sequence step (paragraph 3.2).

### 3.1 Finish Application Steps

#### 3.1.1 Solid Color finish:

1. Sand the body and neck
2. Apply grain filler if desired.
3. Apply 2 coats of sand and sealer
4. Sand to 320 grit
5. Apply primer
6. Sand the primer
7. Apply color coats
8. Apply clear top coats
9. Buff finish

#### 3.1.2 Pigmented Translucent, Gel stain or alcohol dye finish:

1. Sand the body and neck
2. Apply grain filler if desired.
3. Apply 2 coats of sand and sealer
4. Sand to 320 grit
5. Apply stain or dye
6. Apply clear top coats
7. Buff finish

#### 3.1.3 Penetrating Stain or water based dye finish:

1. Sand the body and neck to bare wood
2. Apply grain filler if desired.
3. Apply stain or dye
4. Apply 2 coats of sand and sealer
5. Sand to 320 grit
6. Apply clear top coats
7. Buff finish



**TIP... re-open any of the screw holes in the body. Use a toothpick or small drill held between your fingers to clean out any filler in the holes.**

### 3.2 Explanation of Sequence Steps:

#### 3.2.1 Sanding the Body and Neck

1. Wear a NIOSH-approved respirator and ANSI-approved safety glasses when sanding wood!
2. Before starting the finish on the neck mask off the surface of the fingerboard.

3. Use a flexible sanding block with #150 grit aluminum-oxide sanding paper to sand the guitar body until there is a consistent scratch pattern on the entire surface. Note: DO NOT round over the neck pocket or the body cavities. When hand sanding, always sand in the same direction as the wood grain.
4. Re-sand the entire guitar body and neck with #220 grit sanding paper and lightly round over the outside edges of the body.
5. Wipe the guitar body and neck with a damp cloth to “raise” the wood grain.
6. Wait until the wood is dry and re-sand with #220 grit sandpaper to sand the “raised” grain smooth.

(Note: On a maple fingerboard you can apply a clear finish to the entire neck and fingerboard. Apply several coats and remove buildup on the frets between coats. An easy way to remove the finish buildup on the frets is to take a nail and file a half round slot in the head about the same size as the frets. You can then use this to easily scrape any finish build up.

If the neck has a Rosewood or Ebony fingerboard, be sure to tape off the fingerboard before applying the finish. Behlen’s Fingerboard Oil is a great product for your fingerboard.)

### 3.2.2 Applying Grain Filler

Grain filler will fill in the grain and create flat surface. This is essential if you are trying to get a high gloss finish. Oil based grain filler is recommended. We recommend using Behlen PORE-O-PAC grain filler. For most finishes use natural colored filler. The dyes used in darker fillers may over time find their way through the color coat.

Apply the filler by wiping across the grain. You can use a course cloth or your fingers to wipe the grain in. After it has dried about ten to twenty minutes the excess can be removed with a cloth dampened with mineral sprits. After about an hour repeat the process and let dry overnight. If you have removed most of the excess with mineral spirits the remaining filler on the field of the wood can be sanded off (use #220 again) in a few minutes. It is also a good idea at this time to reopen any of the screw holes in the body. Use a toothpick or small drill held between your fingers to clean out any filler in the holes. The body is now ready for a sand and sealer coating.

### 3.2.3 Applying Sanding Sealer

Sand and sealer is used to give the final coat a level base. It is also helpful in filling scratches which are too deep to sand out. We recommend using Behlen Vinyl Sealer. This comes in aerosol cans and can easily be sprayed on.

### 3.2.4 Solid Color Primer

The last step before applying the color coats is to apply a white primer coat. We recommend using Ohio Valley Nitro Primer. The white background will also let you apply an opaque color coat with less paint. Spray on two coats. When dry you may notice that the surface feels rough. Sand off the roughness with #320 dry and respray. Sand again. If the surface now appears smooth and all grain is opaqued you are ready for the color coat.

### 3.2.5 Burst and Translucent finishes

Bursts and Translucent finishes can be applied using aerosol cans of lacquer toner. Ohio Valley Nitro and Behlen have a full line of Nitrocellulose Lacquer Toners to achieve these finishes.

### 3.2.6 Clear Top coats

Apply several thin coats of the finish, following the manufacturer's instructions. Multiple thin coats usually produce a better quality finish than one heavy coat. Dry sand the entire body with #400 grit wet dry sandpaper after at least three coats of finish have been applied. DO NOT sand through the finish, be careful on the edges. Use a tack cloth to remove sanding residue. Apply more finish, sanding between coats, until the finish is the desired thickness.

### 3.2.7 Buff finish

When the final coat has dried at least a week, preferably a month, remove the masking. Wet sand the finish using #600 grit wet/dry sandpaper with a sanding block, followed with #1000 grit wet/dry sandpaper. Use a clean, absorbent rag to remove excess water. Let the guitar dry completely, then use a tack cloth to remove all residue. Buff the finish by hand or with a buffer, starting with a medium polish and working up to a high gloss polish.

Note: If you use a buffing machine, be careful to avoid going through the finish, especially on the edges.



## Section 4 – Assembly

4.	Assembly .....	- 1 -
4.1	Installing the Neck.....	- 2 -
4.1.1	Neck Positioning: Neck Cavity Insertion .....	- 2 -
4.1.2	Neck Positioning: Centering.....	- 3 -
4.1.3	Neck positioning: neck angle .....	- 3 -
4.1.4	Neck Installation: gluing in place .....	- 3 -
4.2	Installation of the Electronic Components .....	- 1 -
4.2.1	Installing the Wiring Harness .....	- 1 -
4.2.2	Install Pickups.....	- 2 -
4.2.3	Install Volume Controls.....	- 2 -
4.2.4	Selector Switch Wiring and Installation (Reference Figure 4.2.4) .....	- 3 -
4.2.5	Install Covers.....	- 3 -
4.3	Installation of the Bridge Components .....	- 4 -
4.3.1	Installing the Bridge .....	- 4 -
4.3.2	Installing the Tailpiece .....	- 4 -
4.3.3	Install the Pickguard and Pickups.....	- 5 -
4.4	Installing the Tuners & Truss Rod Cover (Figure 4.4).....	- 5 -
4.4.1	Installing the Tuners.....	- 5 -
4.4.2	Installing the Truss Rod Cover.....	- 5 -
4.5	Install the Strings.....	- 5 -
4.6	Installing the Strap Pins.....	- 6 -

### 4. Assembly

After your finish has been applied and thoroughly dried, we can now assemble your guitar. In this section we will permanently install all of the components and solder the wiring for the bridge and neck pickups. Remove all of the protective tape from neck and the neck cavity that you might have used during the Finishing process.



**TIP... use a blanket or large towel on your work area to protect your guitars' finish**

## Section 4 – Assembly

### 4.1 Installing the Neck

#### 4.1.1 Neck Positioning: Neck Cavity Insertion

There are a few things to consider when installing a set neck. First is the position, “in and out”, of the neck in the body. Second, is the alignment of the neck with the center line of the body (Figure 4.1.1-1).

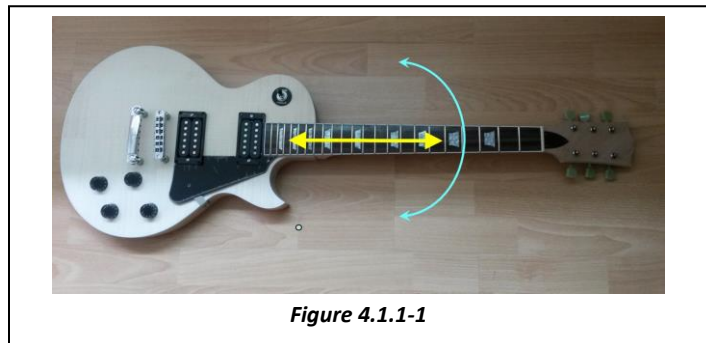
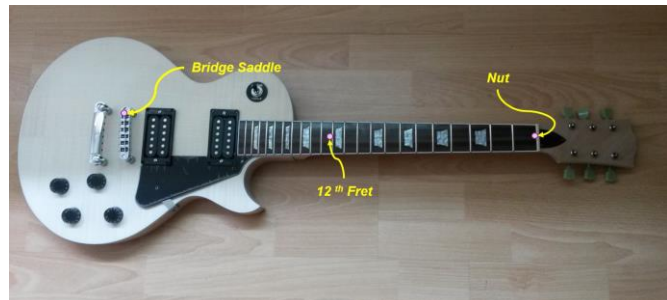

Figure 4.1.1-1

To determine the position of the neck when inserted into the body, it’s important to understand where the neck should be located.

The distance from the nut (edge closest to the fingerboard) to the 12<sup>th</sup> fret is equal to the distance from the 12<sup>th</sup> fret to the bridge (Figure 4.1.1-2).

Use the scale length of the neck and the bridge location to determine the neck placement. **DO NOT simply position the neck so the heel of the neck is at the back of the pickup cavity.** Typically the neck doesn’t reach the back of the cavity and should not be assumed to be the correct neck position.



Distance from Bridge to 12<sup>th</sup> fret = Distance from 12<sup>th</sup> fret to nut

Figure 4.1.1-2

When measuring from the 12<sup>th</sup> fret to the bridge, you want to measure to the saddle on the high E string. (Figure 4.1.1-3) If the bridge holes are drilled with compensation (usually the case on a tune-o-matic bridge) the saddle on the high E string will be closer to the nut than the saddle on the low E string.



Bridge Saddle, top view

Figure 4.1.1-3

To ensure proper alignment of the Neck pickup and the neck, temporarily place the neck pickup in the cavity and attach with 2 screws (Note: the neck might have to be started into the neck cavity before mounting the Neck pickup). Place painters tape on the Body along the Neck pocket and then locate the neck located “in and out” position - mark the tape with a pencil so you can position it correctly when it is glued and clamped.

Remove the Neck pickup.



Figure 4.1.2-1 LP Standard Neck Centering

## Section 4 – Assembly

### 4.1.2 Neck Positioning: Centering

The neck needs to be aligned with the center of the pickup cavities and bridge. This step is the same if you are installing a set neck or a bolt on neck. It's important to get the correct neck alignment, as incorrect alignment of the neck results in the E strings not running parallel to the edges of the fingerboard.

After protecting the finish on the Body, clamp two straight boards to each side of the neck and use a ruler to align the neck with the center of the bridge (figure 4.1.2-1). If the bridge holes are already drilled, the center is known. If they haven't been drilled, align with the center of the pickup cavities. Once you have located the neck, make a mark on the heel of the bridge and pickup cavity so you align it when gluing and clamping.

### 4.1.3 Neck positioning: neck angle

The last thing to check is the neck angle (Figure 4.1.3-1). If the angle is not correct you won't be able to get the correct action. With the neck in the pocket, place a straight edge on the frets. Push the straight edge back until it's over the bridge. The straight edge should be just over the bridge (Figure 4.1.3-2).

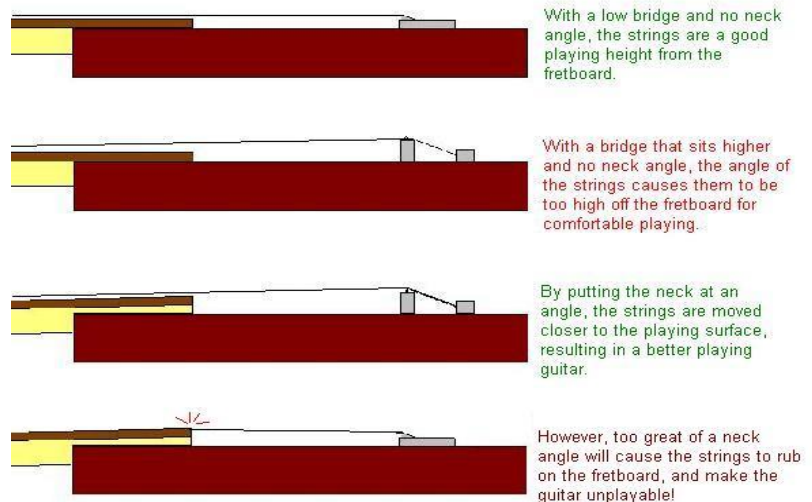
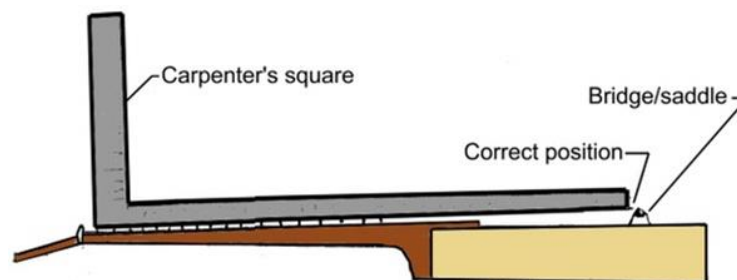

Figure 4.1.3-1 Understanding Neck Angle

### 4.1.4 Neck Installation: gluing in place

Now that the correct positioning and angle have been established for Neck, all that's left is to glue it in place. Use yellow wood glue, align the neck with the marks you've made, clamp in place and allow to dry. Caution should be used when considering the use of glues that expand as they dry (...such as Gorilla glue) as they might expand beyond the seam and damage the finish.



### Proper neck angle

Figure 4.1.3-2 Neck Angle



*Tip... You might also consider using painters tape on the finished portions of the neck and body to protect them from damage during the gluing process.*

## 4.2 Installation of the Electronic Components

After ensuring that the gluing process in previous section is completely dry, you can install the wiring harness, volume & tone controls, selector switch, pickups, and output jack. The wiring harness, controls and output jack come assembled reducing your task to making the final connections between the selector switch & pickups. Wire strippers, solder, soldering iron and small needle nose pliers are required for this section. Figure 4.2 illustrates the harness and configuration of other components, and should be used for reference for this section.



*Tip... Consider running string or fishing line through the Switch pocket to the Audio pocket tunnel first, attaching the harness to the string and pulling the harness through the tunnel*

### 4.2.1 Installing the Wiring Harness

As noted, the wiring harness comes assembled and only requires to be run through various tunnels prior to being connected to other components using shielded wire. Figure 4.2.1-1 details the various Body

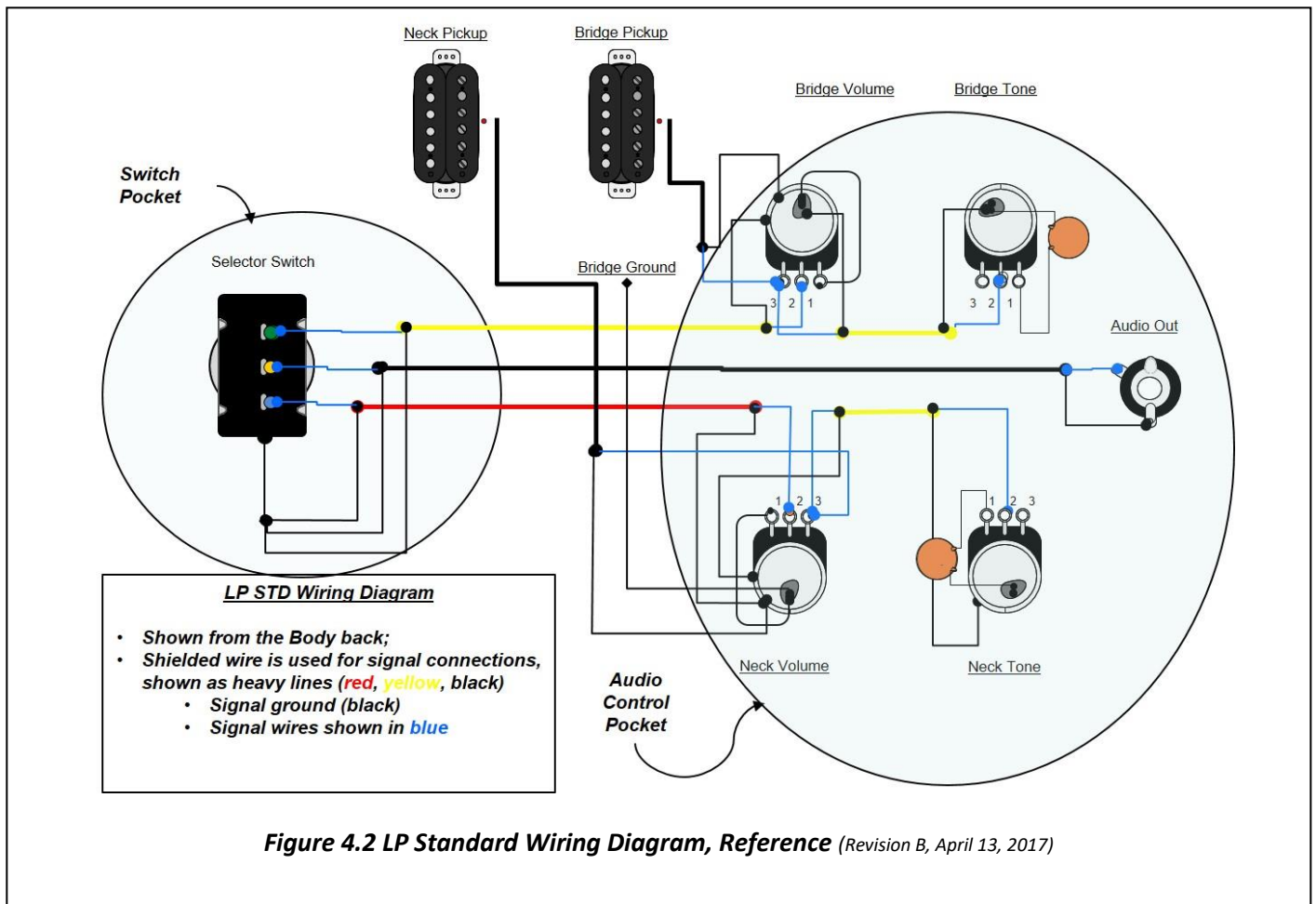

Figure 4.2 LP Standard Wiring Diagram, Reference (Revision B, April 13, 2017)

tunnels (...from a back view). Before starting the installation, inspect all of the harness connections to ensure the integrity of the wiring.

1. Lay the wiring harness over the Body back with the Volume & Tone controls and the Audio jack over the Audio pocket. Carefully run the joined end of the harness from the Audio Control pocket to the Bridge pickup pocket.

2. Continue feeding the harness until the joined end of the harness is in the Switch pocket (Figure 4.2.1-2).

- a. Run the Bridge ground wire from the Neck Volume control through the tunnel to the Bridge Pickup pocket;
- b. Using caution for the Body finish, mount Bridge & Neck Volume controls – use supplied washer & nut, do not tighten;
- c. Mount output jack plate with supplied screws (4);
- d. Mount output jack after carefully inserting the jack through the tunnel to the jack plate - use supplied washer & nut – Figure 4.2.1-2.

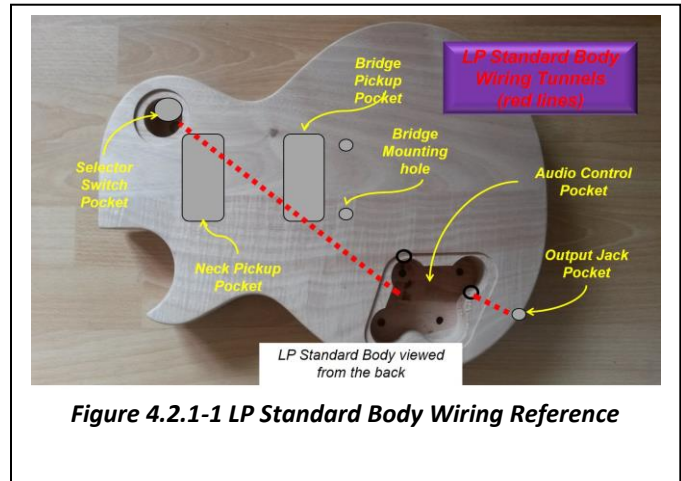

### 4.2.2 Install Pickups

The pickups are installed as shown in Figure 4.2.2 where the Neck pickup has a smaller taper than the Bridge pickup. Also note that the pickups are mounted with the small dimension of the taper pointed toward the neck.

1. Run the shielded pickup wire from the Neck pocket to the Audio pocket via the tunnel – mark the end with tape;
2. Mount the Neck pickup with 2 screws – do not tighten;
3. Run the shielded pickup wire from the Bridge pocket to the Audio pocket via the tunnel;
4. Mount the Bridge pickup with 2 screws – do not tighten.

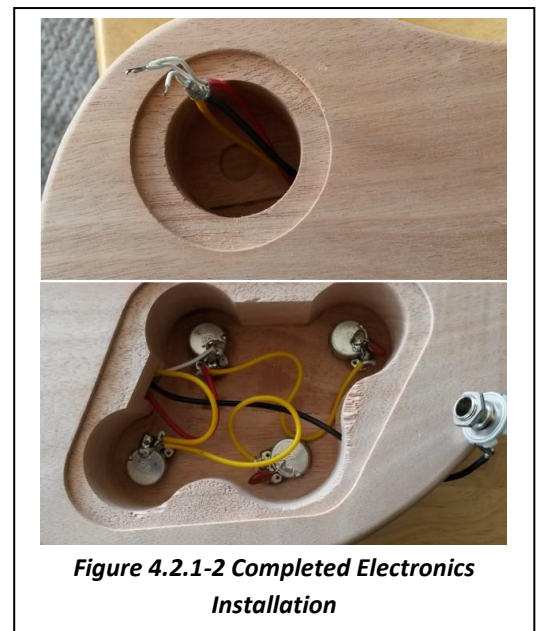

### 4.2.3 Install Volume Controls

1. Solder the Neck pickup signal wire (marked with tape) to pin 3 on the Neck volume control;



2. Solder the Neck pickup shield (ground) wire to the case of the Neck Volume control;
3. Using caution for the Body finish, mount Neck Volume control – use supplied washer & nut, do not tighten;
4. Repeat steps 1-3 for the Bridge Volume control;
5. Recheck all electrical connection to ensure wiring integrity;
6. Carefully tighten all controls in place – take care of your finish!
7. Install the control knobs by turning all controls clock wise, then push on the control knobs with the same orientation of the number scale.

### 4.2.4 Selector Switch Wiring and Installation (Reference Figure 4.2.4)

The Selector switch allows you to choose either the Bridge pickup, the Neck pickup or both for output to your amplifier. Note that the switch position shown in Figure 4.2.4 also represents the installed position of the switch.

1. **Bridge** input:
  - a. Trim & tin **Yellow** shielded wire;
  - b. Solder to upper switch terminal (check Fig. 4.2.4).

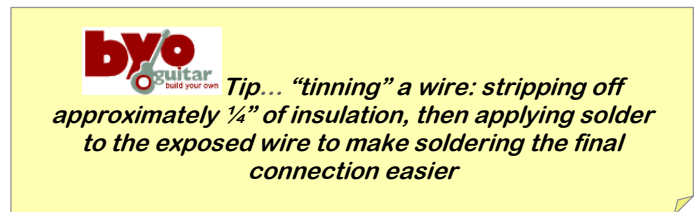

2. **Switch** output:
  - a. Trim & tin **Black** shielded wire;
  - b. Solder to the middle two switch terminals (check Fig. 4.2.4).

3. **Ground:**
  - a. Check the length of the common shield ground wire – solder an additional length of wire (2 – 3 inches) if necessary;
  - b. Solder to switch ground terminal.

4. **Neck** input:
  - a. Trim & tin **red** shielded wire;
  - b. Solder to the lower switch terminal (check Fig. 4.2.4);

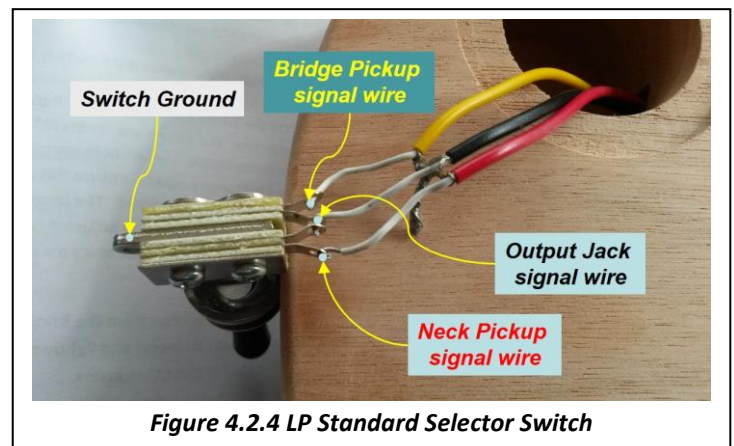

5. While keeping the orientation of the switch action vertical to the Body:
  - a. Insert the switch into the switch pocket – if necessary, gently pull the harness into the Audio pocket to take up any slack;
  - b. Mount the selector switch, including the labeled collar, with supplied washer and nut.

### 4.2.5 Install Covers

1. Install the Audio pocket cover with supplied screws (4);
2. Install the Switch pocket cover with supplied screws (3);

3. Ensure that all clear protective covering is removed.

### 4.3 Installation of the Bridge Components

The LP Standard Bridge consists of 2 components:

1. the Bridge, and
2. the Tailpiece, each with unique mounting inserts.

Figure 4.3-1 shows each of the Bridge components and their orientation to the bridge pickup. The inserts are “press fit” into pre-drilled holes with the lower Bridge insert hole containing the ground wire from the Audio pocket – ensure this wire is present and that the end is **not** tinned/soldered. The length of the ground wire into the mounting hole can be adjusted by gently pulling on the wire from inside the Bridge pocket.

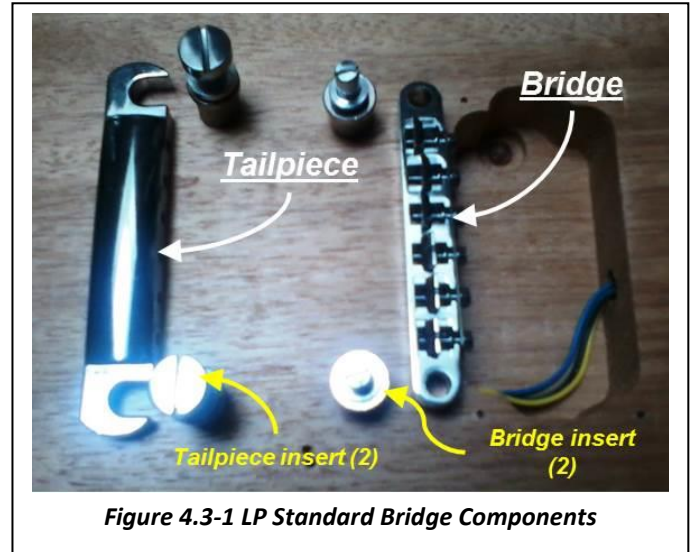

Figure 4.3-1 LP Standard Bridge Components

#### 4.3.1 Installing the Bridge

1. Remove Bridge adjustment screws from the Bridge inserts;
2. Remove the Bridge pickup then run the Bridge ground wire into the Bridge insert hole, spreading the wire strands – position the wire strands so that they will contact the insert when installed. Replace the Bridge pickup;
3. Gently start the Bridge insert ensuring that the ground wire contacts the insert;
4. Place the wooden block on an insert and lightly tap the insert down until it touches the top of the guitar body – use caution as not to damage the Body finish. Repeat for the other insert;
5. Thread the bridge adjustment screws into the inserts;
6. Place the bridge onto the adjustment screws with the individual string adjustment screws facing the neck (Figure 4.3-1).

#### 4.3.2 Installing the Tailpiece

1. Remove the Tailpiece adjustment screws from the Tailpiece inserts, then place the inserts into the holes;
2. Place the wooden block on each insert and lightly tap the insert down until it touches the top of the guitar body. Repeat for the other insert.
3. Thread the tailpiece adjustment screws into the inserts.
4. Slide the tailpiece onto the adjustment screws – hand tighten.

### 4.3.3 Install the Pickguard and Pickups

Now that all of the wiring is complete, the next step is to complete the installation of the Pickups while aligning the Pickguard. Before starting, ensure that the clear protective film is removed from the pickguard.

1. Attach the Pickguard bracket to the Pickup with the supplied nut & bolt;
2. Align the Pickguard notches with the Pickups, the Neck, and the Body contour at the Neck end of the Pickguard;
3. Attach the Pickguard to the Body with the supplied screw (1);
4. Attach the Pickguard bracket to the Body with the supplied screw (1);
5. Attach the Bridge & Neck Pickups with the supplied screws (4 each).

### 4.4 Installing the Tuners & Truss Rod Cover (Figure 4.4)

#### 4.4.1 Installing the Tuners

Each tuner consists of the tuner and collar bushing. The tuners are attached to the headstock with  $\frac{3}{8}$ " wood screws (refer to Section 2.2.1).

1. Gently press the collar bushings (6) into the Headstock – if necessary, apply additional pressure by gently tapping with a wooden block;
2. Place a tuner into a hole on the back of the headstock, noting the orientation toward the end of the Headstock;
3. Secure the tuner to the guitar headstock with the supplied screws;
4. Repeat 2,3 for the additional 5 tuners.

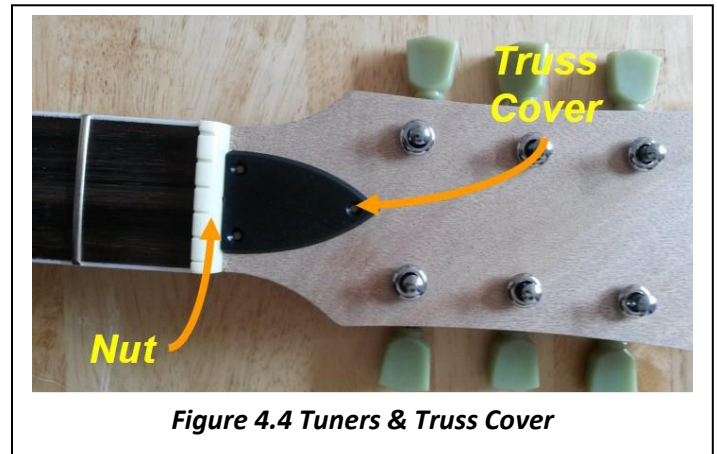

#### 4.4.2 Installing the Truss Rod Cover

Install the Truss rod cover with the supplied screws (3).

### 4.5 Install the Strings

Like most projects, there often several tricks that will make the assembly easier and your guitar better. Properly stringing your guitar is just one of those tricks. Please review the following YouTube video:

<http://www.youtube.com/watch?v=tlfP3v-bxwE>

Although the video addresses restringing a guitar, the principles and techniques will help you string your guitar – as well as provide a visual for the stringing of your guitar.

5. Carefully uncoil each of the strings (6), ensuring that the strings do not have a kink.
6. Run the low E string (largest diameter string) through the upper hole in the Tailpiece. Carefully seat the string ball in the Tailpiece.



## Section 4 – Assembly



7. Adjust the hole in the first tuner to be perpendicular to the neck.
8. Run the string upward over the Bridge saddle and through the hole in the tuner till snug on the neck; gently pull the string backward for a length of about 2 frets (check the video).
9. Run the string forward (toward the end of the headstock) wrapping the around the tuner and under the sting; bend over the string (toward the end of the headstock).
10. Tighten the string down the tuner; when the string is snug against the 1<sup>st</sup> slot in the nut, trim the excess string.
11. Repeat steps 2-6 using the next smaller diameter string & the tuner.

### 4.6 Installing the Strap Pins

Secure each strap pins (2) in the pre-drilled holes with the supplied screws (2ea, 1”).

*Assembly of your Guitar is now complete – let's set it up!!*

5 Initial setup ..... - 1 -

5.1 Adjust the Guitar Neck: Truss Rod..... - 2 -

5.1.1 Check the Neck..... - 2 -

5.1.2 Adjusting the Truss Rod ..... - 2 -

5.2 String Lubrication..... - 2 -

5.3 Adjusting the Action..... - 3 -

5.3.1 The Nut..... - 3 -

5.3.2 Bridge Saddle Adjustment..... - 3 -

5.4 Pickup Height (Figure 5.4)..... - 4 -

5.4.1 Bridge pickup: ..... - 4 -

5.4.2 Neck Pickup: repeat steps 1.1 through 1.3 (above) on the neck pickup, noting measured heights. - 4 -

5.5 Intonation (Figure 5.5) ..... - 4 -

5.6 ...Other Hints..... - 5 -

## 5 Initial setup

In this section, we will address the initial setup for:

1. Adjusting the Neck (Truss Rod);
2. Adjusting the String Action (string height);
3. Adjusting the Pickup heights;
4. Adjusting the Intonation.

These adjustments will provide preliminary settings from which you can fine tune the sounds to your individual playing style. As with previous sections,  references are included for additional clarification of specific adjustments.



reference...check out the following



references that can be helpful in tuning your guitar:

- ✓ **tone generator for tuning:** [http://www.get-tuned.com/online\\_guitar\\_tuner.php](http://www.get-tuned.com/online_guitar_tuner.php) & <http://www.guitarforbeginners.com/onlinetuner.html>
- ✓ **downloadable “musical instrument tuner” from PerfectPitch (<http://www.nch.com.au/tuner/>) that will allow visualization of string adjustments**

String up the guitar with your desired gauge of strings – check the tuning.

### 5.1 Adjust the Guitar Neck: Truss Rod

The first major procedure in the setup is adjusting the neck relief. Neck relief simply refers to how much the neck bows. The degree of bowing in the neck is a matter of personal preference and is correlated to your playing style.

#### 5.1.1 Check the Neck

Get a ruler or straightedge that is at least as long as the neck, but not so long that it reaches all the way from the nut to the saddles. If you can't get one between these lengths, and are willing to sacrifice a ruler, get one that's too long and cut it to length.

Alternatively, you can just cut a little out of one edge so that you can still make full use of the other edge of the ruler. Now lay the edge of the ruler along the frets (don't rest it on top of the nut, saddles, pickups or pickup surrounds).

Using a feeler gauge or high resolution metal ruler, measure the string height (the gap between the ruler/string and the top of the fret) at about the 8th fret. The string height should be approximately 1/8' (0.012") - simply slide the feeler gauge into the gap to see if it is too big/small.

#### 5.1.2 Adjusting the Truss Rod

Tightening the truss rod adjustment bolt will cause the neck to warp backward (too much and the strings will buzz on the frets), and loosening it will cause it to bow forward (giving more relief.).

CAUTION: If you find that the truss rod is very difficult to turn, then stop. It may be that there is a problem with the neck or the truss rod and you may damage the guitar by forcing it.

Sight down the edge of the fingerboard from behind the headstock, looking toward the body of the guitar.

1. If the neck is too concave (action too high), turn the truss rod nut clockwise to remove excess relief (only adjust ¼ turn at a time).
2. If the neck is too convex (strings too close to the fingerboard), turn the truss rod nut counter-clockwise to allow the string tension to pull more relief into the neck.
3. Check the tuning, then re-check the gap with the feeler gauge and re-adjust as needed.

### 5.2 String Lubrication

Lubricate the contact points of a string's travel to ensure tuning stability and reduce string breakage.

Lubricate:



*reference: ...check out the following*



*references for adjusting the Truss rod:*

- ✓ <http://www.youtube.com/watch?v=PHHepmTX3So>
- ✓ <http://www.youtube.com/watch?v=4j3QryKIXrc>



**TIP... do the neck adjustment in a series of intermediate steps and re-tune your guitar before each step – different tension on the strings changes the adjustment of the neck**

## Section 5 – Setting Up Your Guitar



1. string/saddle contact points with a light machine oil (...such as 3-in-1 oil because it contains anti-rust and anti-corrosive properties) every time you change strings.
2. string trees should also be lubricated; a small amount of lip balm applied with a toothpick works well.

### 5.3 Adjusting the Action

#### 5.3.1 The Nut

Setting the string action that is right for you starts at the nut. The slots should already be close, but you might want to make some adjustments.

1. Push the sixth string down between the second and third fret. The space between the first fret and the bottom of the string should be about .006 or just about the thickness of two sheets of paper. If the gap is wider than .006" you should deepen the slot with a small needle file. **DO NOT FILE TOO DEEP!** Make sure when you file, the file is angled down toward the headstock. This will ensure the string sits on the edge of the nut closest to the fretboard.
2. Repeat the procedure for the remaining 5 strings.



*reference...check out the following references for adjusting the "Nut Action":*

- ✓ <http://www.youtube.com/watch?v=zz9UKX2lcxw>



*TIP...check out the following references for adjusting the "Bridge Action Height":*

- ✓ <http://www.youtube.com/watch?v=oWpnW8ICn-U>

#### 5.3.2 Bridge Saddle Adjustment

This will adjust the height of the strings over the 12<sup>th</sup> fret. Minor adjustments are made by raising or lowering the bridge. This adjustment is a matter of personal preference. There should be a gradual increase in height from the first string to the sixth string.

The question here is how high to make the bridge. This is personal choice.

Adjusting saddle height is very easy on the Explorer guitar. Since the bridge can only be adjusted at each end, there is no need to adjust each saddle individually.



*TIP... most factories set action at 3/32" to 7/64" on the bass E string at the 12th fret and 2/32" to 5/64" on the treble E.*

1. Check and, if necessary, adjust the low (thick) E string height. Do this by adjusting the height of the bridge at the thick E string end. This is done by rotating the Bridge insert adjustment counter-clockwise to raise the bridge or clockwise to lower it. Adjust the height until string doesn't buzz on any fret from being too low, but low enough that you can play up and down the neck easily. There's usually a sweet spot where you can just start to detect some buzzing and you can leave it just a tiny bit higher than that. Be careful if you use a tool as it is easy to slip and damage the finish on your guitar.

2. Now do the exact same procedure for the high (thin) E string end of the bridge.
  
3. Play the guitar a little bit to see if any of the other strings are buzzing. If, say, the A string is still buzzing, then raise up the end of the bridge nearest to that string a little bit.

### 5.4 Pickup Height (Figure 5.4)

Each pickup is adjustable on the bass and treble sides. Finding the best combination of tone and volume will require some experimentation.

#### 5.4.1 Bridge pickup:

1. Press the 1<sup>st</sup> string onto the last fret and hold;
2. Using a machinist ruler, measure the distance from the top of the pole to the bottom of the 1<sup>st</sup> string – note bass measurement;
3. Repeat #1.1 & #1.2 on the 6<sup>th</sup> string – note the treble measurement;

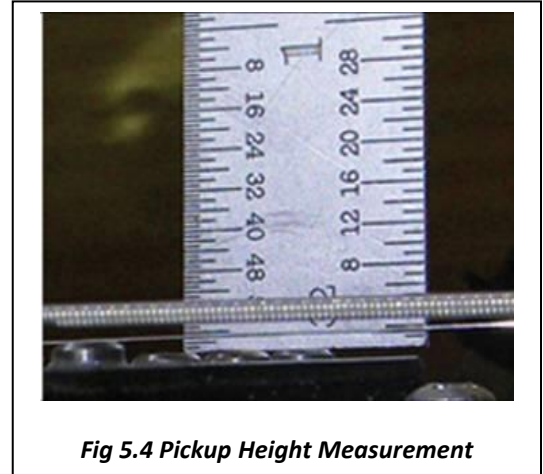

Fig 5.4 Pickup Height Measurement

**5.4.2 Neck Pickup:** repeat steps 1.1 through 1.3 (above) on the neck pickup, noting measured heights.

<i>Table 5.4 Pickup Height Guide</i>		
<i>Pickup</i>	<i>1<sup>st</sup> String</i>	<i>6<sup>th</sup> String</i>
<b>Bridge</b>	<b>2/64"</b>	<b>3/63"</b>
<b>Neck</b>	<b>3/64"</b>	<b>4/64"</b>

Table 5.4 Bridge and Neck Pickup Heights

Using Table 5.4 as a reference, adjust the height of the pickups by turning the adjustment screws for the bridge, & neck pickups – recheck string heights after each adjustment.



reference...check out the following  
adjusting Intonation:

✓ <http://www.youtube.com/watch?v=CqN7xJD1rdE>



### 5.5 Intonation (Figure 5.5)

Adjustments should be made after all of the above have been accomplished.

1. Set the pickup selector switch in the middle position.
2. Turn the volume & tone controls to maximum.
3. Check tuning. Check each string at the 12th fret, harmonic to fretted note (make sure you are depressing the string evenly to the fret, not the fingerboard).

## Section 5 – Setting Up Your Guitar



4. If sharp, lengthen the string by adjusting the saddle back. If flat, shorten the string by moving the saddle forward.

### 5.6 ...Other Hints

There are a few other things that you can do to optimize your tuning stability:

1. Each time you play your guitar, before you do your final tuning, play for a few minutes to allow the strings to warm up. Metal expands when warm and contracts when cool. After you've played a few riffs, you can then do your final tuning;
2. Wipe the strings, neck and bridge with a lint-free cloth after playing;
3. When transporting or storing your guitar, even for short periods, avoid leaving it anywhere you wouldn't feel comfortable yourself.

Remember, guitars are tempered instruments! Re-tune, play and make further adjustments as needed.

We hope you have enjoyed building your guitar! If you have any questions along the way please email us at [sales@BYOGuitar.com](mailto:sales@BYOGuitar.com).

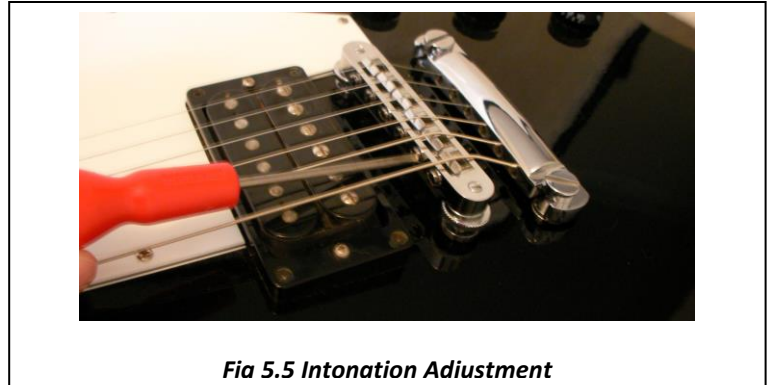

*Fia 5.5 Intonation Adjustment*



*Custom Shop Products*

